

E1601 rev.2.00 - 10/07/2020



Micrometric valves
GAF

GENERAL WARNINGS



- Each manual, including this one, is an integral part of the ESA catalog.
- Each manual may contain errors or give rise to interpretative doubts. ESA invites you to report any interpretative errors or doubts but will not be able to consider such occurrences as the cause of any disputes.
- This manual and all its parts (logos, texts, photos, tables, graphics, etc ...) cannot be reproduced or modified in whole or in part without the written consent of ESA.
- The technical information relating to the design, installation, regulation and operation of the combustion plant intended to host ESA products must be previously shared with ESA. Failing this, ESA declines all responsibility in relation to damage to things and people deriving from improper use of the products.
- In general, a combustion plant is not designed for drying oven refractories. In case of use, ESA declines any responsibility in this regard.
- The performance of the products indicated in each manual is the result of tests conducted using ESA equipment at our Research and Development Center, under certain operating conditions. These performances cannot be guaranteed using other equipment or outside the aforementioned conditions.
- The design, installation, adjustment and operation of a combustion plant require compliance with all applicable safety standards and regulations. ESA declines all responsibility in relation to its products, if used in plants or in circumstances in which the regulations in force in the place of use are not respected.
- All installation, maintenance, ignition and calibration operations must be carried out by qualified personnel in compliance with all the points indicated in this manual. The indications given in this document do not exempt the customer/user from observing the general and specific legal provisions.
- All personnel responsible for checking and operating the device must be informed of the contents of this manual and must strictly follow its instructions. The operator must wear suitable clothing and PPE according to the legal requirements, respecting the general safety and risk prevention rules. If clarifications, additional information or training are required, contact the ESA sales offices.
- ESA reserves the right to modify the technical characteristics of the products by updating the relative manual at any time and without notice. By consulting the website **www.esapyronics.com** it is possible to download the manuals updated to the latest revision in Italian and English.

LOGISTICS AND DISPOSAL



- **Transport:** protect the equipment from shocks, vibrations, atmospheric agents, etc... Upon receipt of the product, check the labeling in accordance with the order and promptly notify any discrepancies and/or transport damage.
- **Storage:** store the product in a suitable place, according to the product specifications.
- **Packaging:** the material used must be disposed of according to local regulations.
- **Disposal:** comply with local legislation on this matter.

CERTIFICATIONS



EAC for the Eurasian market (Russia, Belarus and Kazakhstan).

- ESA adopts the Quality System certified by DNV GL in compliance with the **UNI EN ISO 9001** standard.
- ESA adopts the Code of Ethics and Behavior pursuant to Legislative Decree **231/01**.
- ESA products are designed, manufactured and controlled in compliance with the Directives/Regulations, in particular **UNI EN 746-2** "Industrial thermal process equipment - Part 2: Safety requirements for combustion and for the handling and treatment of fuels" harmonized to the Machinery Directive **2006/42/EC**.

DESCRIPTION

The GAF series identifies non-sealing manual micrometric valves designed to quickly and accurately regulate gas and air flow rates in low pressure ducts. They are available in different configurations, with threaded or welded flanges.

CHARACTERISTICS

Technical features

Fluids:	Non-aggressive gases according to EN437 (standard execution) and hot air and flue gases (special execution)	
Maximum working pressure:	450 [mbar] @ 60 [°C] 180 [°WC] @ 140 [°F]	200 [mbar] @ 180 [°C] 80 [°WC] @ 356 [°F]
Maximum fluid temperature:	180 [°C] 356 [°F]	
Operating temperature:	-20 ÷ +60 [°C] -4 ÷ +140 [°F]	
Storage temperature:	0 ÷ +25 [°C] 32 ÷ 77 [°F]	
Leakage with closed valve:	less than 0.5%	
Available sizes:	from 1/2 "to 2" according to ISO 7/1, NPT threads on request, from DN65 to DN100 flanged	
Type of regulation:	Micrometric manual	

Construction features

Valve body:	G25 cast iron
Valve body treatment:	Phosphating
Adjusting piston:	AVP galvanized (special materials on request)
Closing cap	Aluminum
Shaft tightness:	NBR O ring (special seals on request)

Accessories

Flange gaskets:	AFM-34 / X-Plus
Connection flange:	PF, PFP, PFF and PSP Series - E5701

GALLERY



GA



GAF threaded



GAF flanges to be welded

FLOW CHART FULLY OPEN VALVE

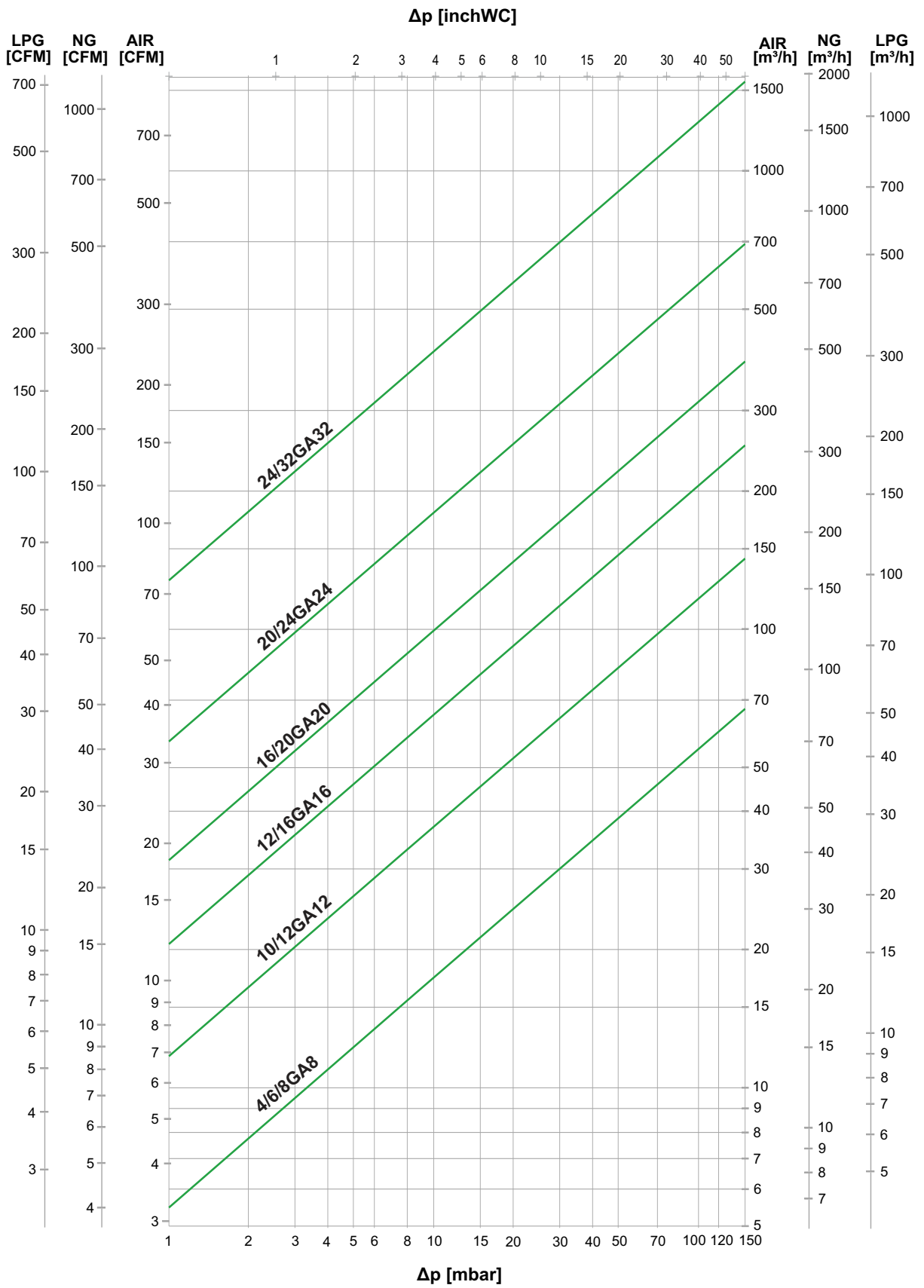

T=0 [°C] e P_s=1013 [mbar]

G1601101

VELOCITY GRAPH

To correctly size noise and pressure drops, the maximum recommended speed of the flow inside a pipe must be limited to 30 [m/s] or 5920 [ft/min] (ESA recommends <20 [m/s] or 3950 [ft/min]). The speeds are calculated taking into account carbon steel pipes according to the standard EN 10255 Medium Series. Different pipe thicknesses will correspondingly result in different flow rates.

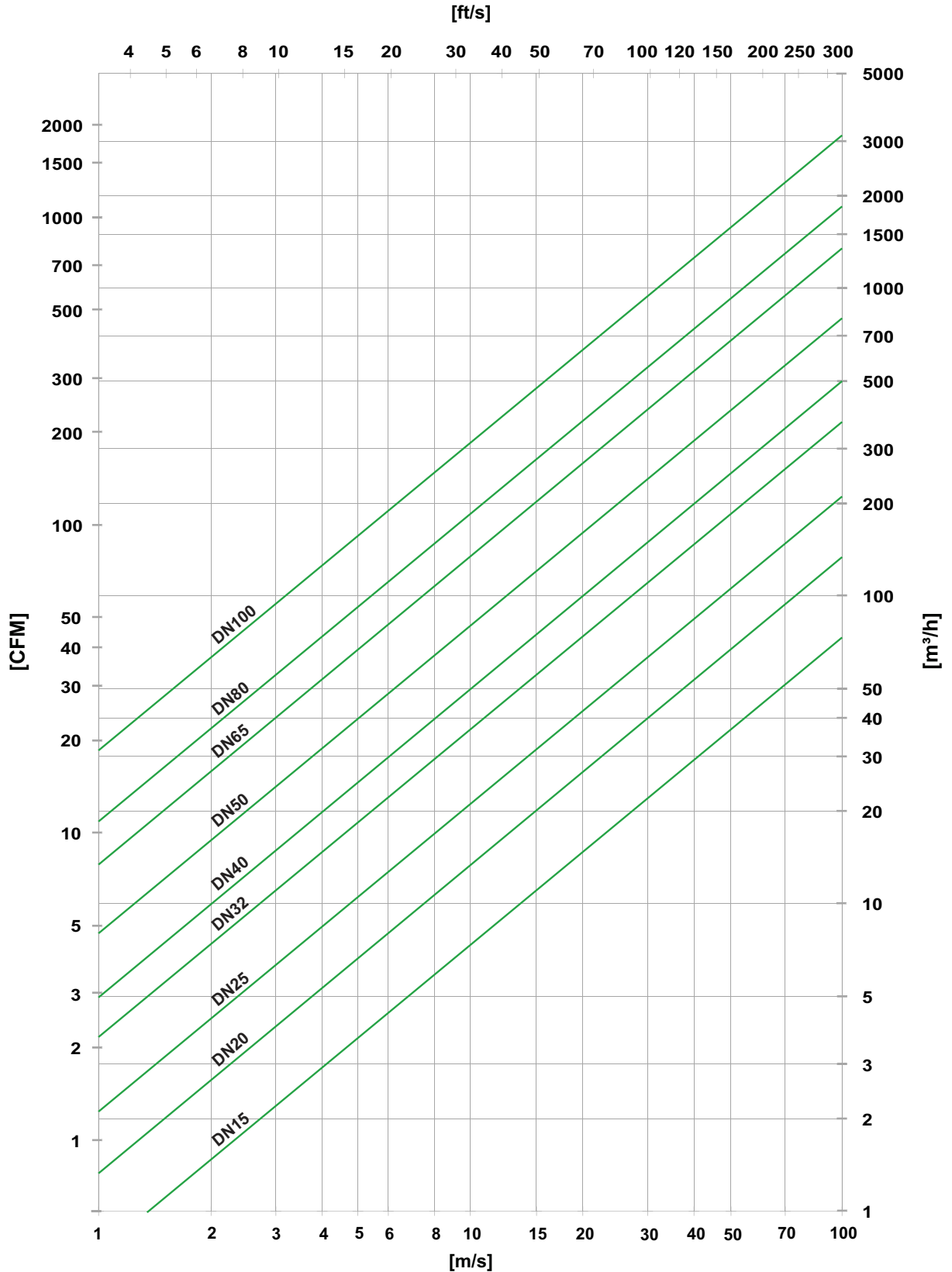

G1602102

CALCULATION OF THE FLOW OF A GAS OTHER THAN AIR

The flow rate diagram refers to the three main fluids used in applications relating to combustion plants (air, natural gas and LPG).

To calculate the valve flow rate, relative to a gas other than those listed above, starting from the air flow rate resulting from the graph, the following formula can be used:

$$Q_{\text{gas}} = \sqrt{\frac{1.2928}{\rho_{\text{gas}}}} * Q_{\text{air}}$$

T= 0 [°C] and Ps 1013

knowing the density of the gas whose flow rate is to be calculated. Typical densities of some common gases can be found below:

Gas type	ρ_{gas} @0 [°C] [Kg/m ³]	MM molecular mass [-]
Air	1.2928	28.96
Natural gas	0.78	18.2
LPG (95% propane)	2.01	45.50
Nitrogen	1.25	28.01
BFG (60% N ₂ , 24% CO, 12% CO ₂ , 4% H ₂)	1.29	28.89
COG (50% H ₂ 30% CH ₄ 3% C _n H _m 7% CO 3% CO ₂ 7% N ₂)	0.553	12.39
CO ₂	1.976	44.01
Exhausted from NG (3% O ₂)	1.243	27.85
Exhausted from LPG (3% O ₂)	1.271	28.47

EX.1

To calculate the flow rate of a 24GAF24 valve at 10 [mbar] of Δp , used for natural gas, the air flow rate is obtained on the graph (specifically, it reads about 170 [m³/h]).

Using the above formula:

$$Q_{\text{gas}} = \sqrt{\frac{1.2928}{0.78}} * 170 = 218 \text{ [m}^3\text{/h]}$$

This simplified formula calculates a volumetric flow rate in [m³/h]; to have a reference in [Nm³/h] the following parameters must be taken into consideration:

- P_{in} input pressure
- Fluid temperature
- Altitude of the application (this value changes the P_{atm})

The following exercise explains the conversion process between [m³/h] and [Nm³/h].

EX.2

To calculate the flow rate of a 24GAF24 valve at 10 [mbar] of Δp with an inlet pressure of 80 [mbar], used for preheated air at T_{ref} = 50 [°C], the air flow rate is obtained on the graph in [m³/h]:

$$Q_{\text{air}} [0 \text{ °C}] = 170 \text{ [m}^3\text{/h]}$$

Now it is necessary to transform [m³/h] into [Nm³/h], using the following procedure.

Obtain the density of the gas at the operating temperature and pressure with the following formula:

$$\rho_{\text{N}_2} [50 \text{ °C}] = \frac{P_{\text{atm}} + P_{\text{in}}}{\left(\frac{8314}{\text{MM}}\right) * T [\text{°K}]}$$

CALCULATION OF THE FLOW OF A GAS OTHER THAN AIR

where is it:

- P_{atm} atmospheric pressure at a given altitude.
- P_{in} pressure at the valve inlet.
- MM molecular mass of the gas used.
- T temperature in degrees Kelvin of the gas.

which, with the project data it results:

$$\rho_{N_2} [50 \text{ }^\circ\text{C}] = \frac{101325 + 8000}{\left(\frac{8314}{28.01}\right) * (50 + 273.15)} = 1.139 \text{ [kg/m}^3\text{]}$$

Now we calculate the flow rate with the following formula:

$$Q_{[Nm^3/h]} = \frac{\rho_{N_2} [50 \text{ }^\circ\text{C}]}{\rho_{air \ 0} [^\circ\text{C}]} * Q_{[m^3/h]}$$

Which with the project data results:

$$Q_{[Nm^3/h]} = \frac{1.139}{1.2928} * 170 = 149.7 \text{ [Nm}^3\text{/h]}$$

To select the size of a valve starting from a plant data with flow rate in $[Nm^3/h]$, the reverse procedure is carried out, obtaining the density at a given temperature and using the inverse formula with respect to the previous one:

$$Q_{[m^3/h]} = \frac{\rho_{gas \ 0} [^\circ\text{C}]}{\rho_{gas \ Tref}} * Q_{[Nm^3/h]}$$

VALVE SIZING

To size the valve correctly, proceed as follows:

- selected the diameter of the pipe according to the maximum speed to be respected ($<20[m/s]$).
- considering that, for optimal valve regulation, the Δp must be approximately 15 ÷ 20% of the valve inlet pressure ($a = \Delta p/p_1 = 0.15 \div 0.20$) and that the pressure downstream of the valve p_2 is a known variable, calculate the Δp of the valve according to the following formula:

$$\Delta p_{100\%} = \frac{a * p_2}{(1 - a)}$$

Ex. Select an air valve with $p_2 = 45 \text{ [mbar]}$ and flow rate $V = 70 \text{ [Nm}^3\text{/h]}$. In order not to exceed the recommended flow rate, DN50 pipes can be used.

The pressure drop will be:

$$\Delta p_{100\%} = \frac{0.2 * 45 \text{ [mbar]}}{(1 - 0.2)} = 11.25 \text{ [mbar]}$$

From the diagram of the GAF valves it appears that the valve that guarantees the required flow rate is DN50 (16GAF16). If the size of the piping does not correspond to that of the valve, use reducing fittings.

The inlet pressure to the pipeline must therefore be:

$$p_1 = \Delta p_{100\%} + p_2 = 45 + 11.25 = 56.25 \text{ [mbar]}$$

This datum, added to other line pressure losses possibly present upstream of the valve, will be used for the correct sizing of the inlet pressure to the supply line.

WARNINGS

The GAF series valves are regulating and not safety devices, the tightness is guaranteed only for leaks to the outside, they are not suitable for the interception of fuels and are not part of the protection system according to EN746-2.

Any modification or repair carried out by unauthorized personnel compromises the safety of the application and automatically invalidates the general warranty conditions.

For correct use, observe the following warnings.



- Make sure that all system features are compatible with the valve specifications: hydraulic connections, type of fluid, operating pressure, flow rate, temperature range, etc...
- Avoid excessive amounts of sealant in case of threaded connections, which could enter the valve.
- Before proceeding with any installation or service operation, close the upstream air/gas flow and disconnect the power supply.
- If the valve accidentally falls, it can suffer permanent damage; in this case it is mandatory to replace the equipment.
- Avoid water hammer.
- Any dirt chips, welding residues or sealing materials must not come into contact with the internal parts of the valve.
- It is good practice to install a filter upstream of the supply piping.
- Do not damage the sealing surfaces of the flanges.



- In insulated pipes, check that there is sufficient space for tightening the bolts.
- Do not insulate the valve with thermal insulation.
- Check the thermal resistance of the gaskets.

GAF INSTALLATION

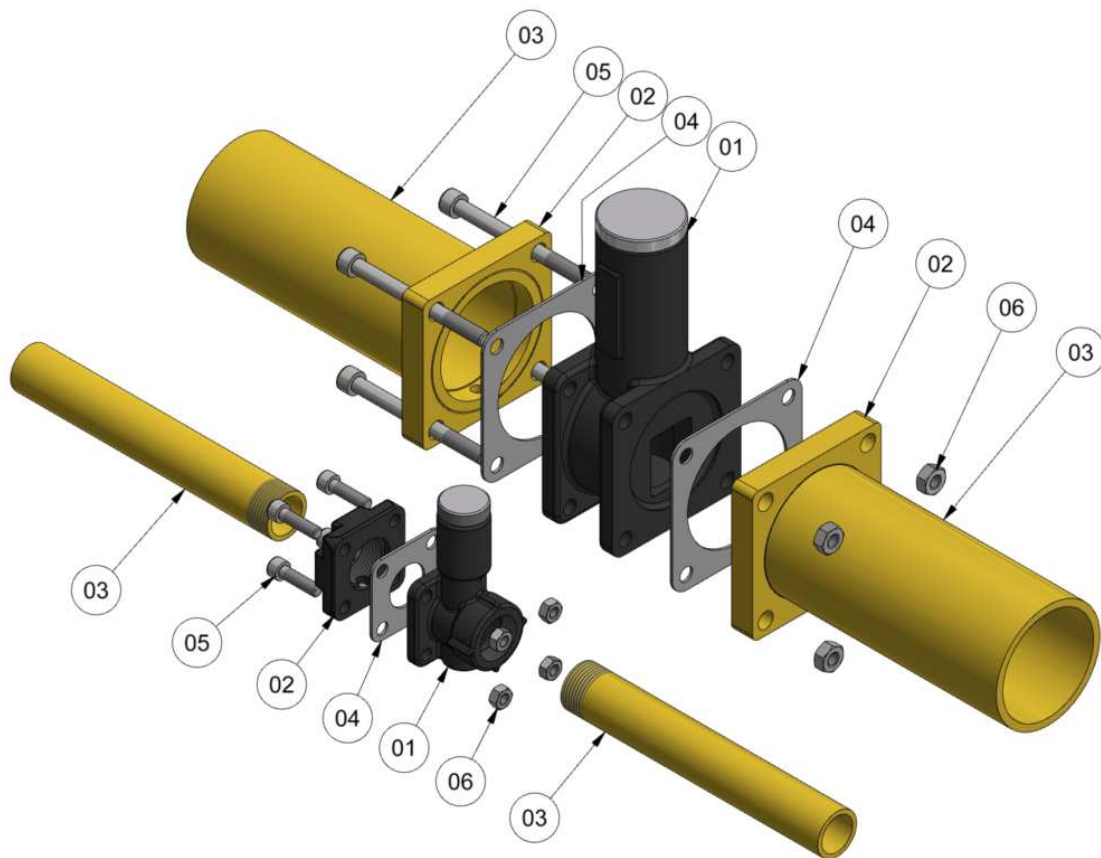

D1601I01

The valves of the GAF series are equipped with coupling flanges and gaskets suitable for the type of valve and the application.

The valve can be installed horizontally or vertically, respecting a straight section of upstream and downstream piping of at least 2xDN.

Maintain a distance from the surrounding obstructions that allows the correct adjustment of the micrometric screw, free circulation of air and proper maintenance.

Connect the pipes (**pos.03**) to the flanges (**pos.02**). Depending on the version, the connection can be welded or threaded:

- A** - For threaded connection, use thread sealing paste, taking care not to introduce excess sealant inside the valve.
- For solder connection, perform a tight seal and eliminate any residues.

- B** Check the correct alignment of the pipes (**pos.03**) and the spacing between the flanges (**pos.02**), in order to avoid exerting tension on the pipes during the tightening phase.

- C** Make sure that no foreign body is present inside the valve (**pos.01**) or in the pipes (**pos.03**) before carrying out the assembly.

- D** Insert the bolts (**pos.05**) in the fixing holes of one of the two flanges (**pos.02**) and position the valve (**pos.01**) and the first gasket (**pos.04**); then fit the remaining nuts (**pos.06**), washers and gasket (**pos.04**).

- E** Use only suitable tools and avoid excessive tightening. For the installation of the threaded version, do not screw the valve on the pipe by levering the adjustment stem.

- F** After assembly, check the correct opening and closing movement of the valve and return the adjustment screw to the closed position.

- G** The correct installation and sealing of the valve and its gaskets towards the outside must be performed through a functional test at a test pressure 1.1 times the working pressure.

SEQUENCE OF SCREWS TIGHTENING ON ATTACHMENT FLANGES

Tighten the bolts and nuts in a crisscross pattern, using a minimum of three tightening passes and maximum bolt stress as defined in the tables below.

STEP 1: Torque up to a maximum of 30% of the final torque value according to the torque sequence. Make sure the gasket is compressed evenly.

STEP 2: Torque up to a maximum of 60% of the final torque value.

STEP 3: Torque at final torque value (100%).

After completing the three basic torque steps, retighten the nuts at least once using the final torque crosswise until no further nut rotation is observed.

THREADED FLANGES

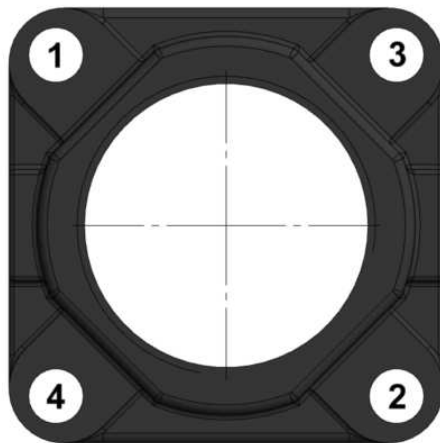

WELDING FLANGES

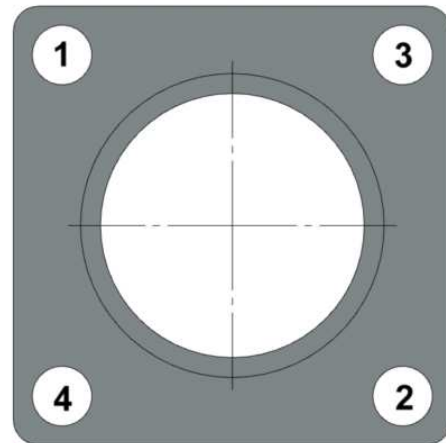

D1601102

4 bolt flange: 1,2,3,4

DN [mm]	PN 0.5	
	[Nm]	[Ft/lbs]
15/20/25	30	22
32/40/50	50	37
65/80/100	50	37
125/150	70	52

GAF REGULATION AND CALIBRATION

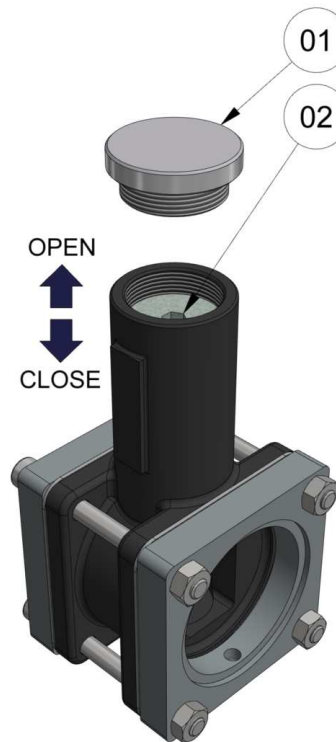

D1601103

To calibrate the GAF valves, act on the adjustment screw located inside the valve body. During the adjustment phase, monitor the pressure and flow rate parameters of the pipeline using suitable instruments (calibrated flanges, differential pressure gauges, etc...).

- A** Remove the protection cap (**pos.01**) on the valve body.
- B** Turn the adjustment screw (**pos. 02**) to the desired position. To open the valve, act counterclockwise, to close the valve, act clockwise.
- C** Put the protection cap (**pos. 01**) back on the valve body.
- D** If several valves are adjusted on the outlets of the same duct, check that the previously performed calibrations have not undergone any changes, otherwise carry out the adjustment again.

MAINTENANCE

All maintenance operations, due to the short times and working conditions in which they can be carried out, involve a greater risk of errors and accidents and must therefore be carried out after careful and in-depth analysis of the risks for the operators and for the process, putting all necessary precautions in place.

Operation	Frequency [months]	Note
Gaskets integrity	12	Check that there are no leaks to the outside with adequate leak detection liquids. In case of replacement, follow the instructions given in the INSTALLATION paragraph.
Bolt tightening	12	6 months in vibration applications.
Valve calibration	12	Check the pressure and flow rate parameters of the pipeline using suitable instruments (calibrated flanges, differential pressure gauges, etc...). If necessary, repeat the calibration operations.
Valve maintenance	12	Check the condition of the internal elements, clean with a clean cloth and compressed air, taking care not to damage the internal parts.

Component	Useful life [years]	Command cycles
Control systems for valve tightness	10	250.000
Pressure switches	10	N/A
Burner control device	10	250.000
UV flame sensor / electrodes	10.000 operating hours	
Gas regulators	10	N/A
Solenoid valves	10	250.000
Relief valve	10	N/A
Regulation valve	10	N/A
Regulators	10	N/A
Servomotors	10	N/A

GAF OVERALL DIMENSIONS THREADED MODEL

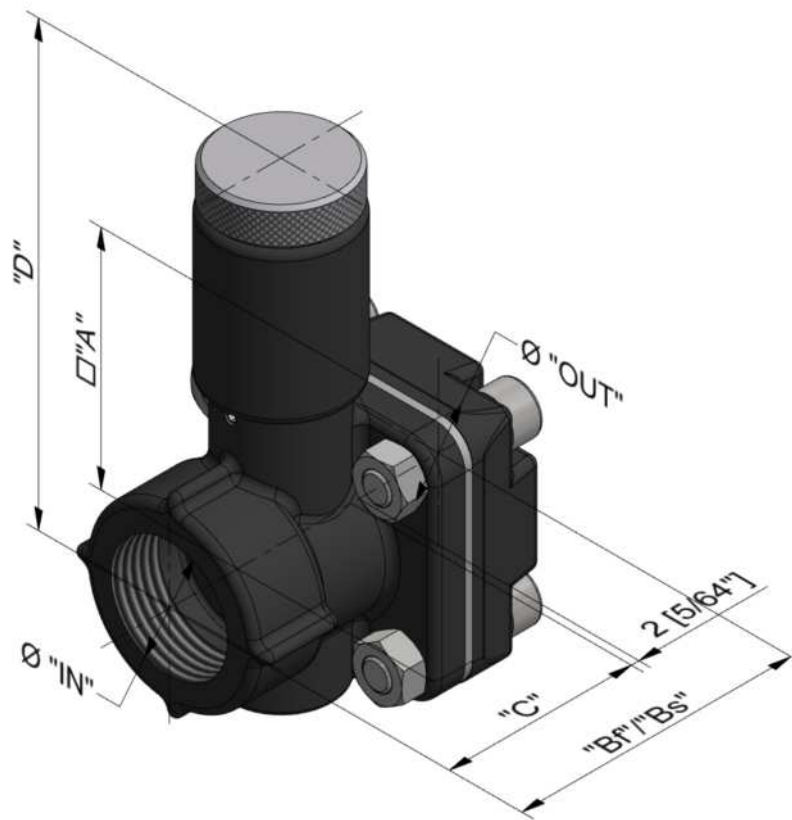

D1601I04

Model	Ø "IN" (*)	Ø "OUT" (*)	Ø "A"		"Bf"		"Bs"		"C"		"D"		Mass	
			[mm]	[inch]	[mm]	[inch]	[mm]	[inch]	[mm]	[inch]	[mm]	[inch]	[Kg]	[lbs]
4GAF6	Rp 1/2"	Rp 3/4"	60	2.23/64	71	2.51/64	68	2.43/64	48	1.57/64	118	4.41/64	1.25	2.75
6GAF6	Rp 3/4"	Rp 3/4"	60	2.23/64	71	2.51/64	68	2.43/64	48	1.57/64	118	4.41/64	1.24	2.73
6GAF8	Rp 3/4"	Rp 1"	60	2.23/64	71	2.51/64	68	2.43/64	48	1.57/64	118	4.41/64	1.20	2.64
8GAF8	Rp 1"	Rp 1"	60	2.23/64	71	2.51/64	68	2.43/64	48	1.57/64	118	4.41/64	1.18	2.60
10GAF10	Rp 1.1/4"	Rp 1.1/4"	76	2.63/64	92	3.5/8	80	3.5/32	60	2.23/64	148	5.53/64	2.15	4.74
10GAF12	Rp 1.1/4"	Rp 1.1/2"	76	2.63/64	92	3.5/8	80	3.5/32	60	2.23/64	148	5.53/64	2.15	4.74
12GAF12	Rp 1.1/2"	Rp 1.1/2"	76	2.63/64	92	3.5/8	80	3.5/32	60	2.23/64	148	5.53/64	2.03	4.48

(*) NPT threads on request

GAF OVERALL DIMENSIONS FLANGED MODEL

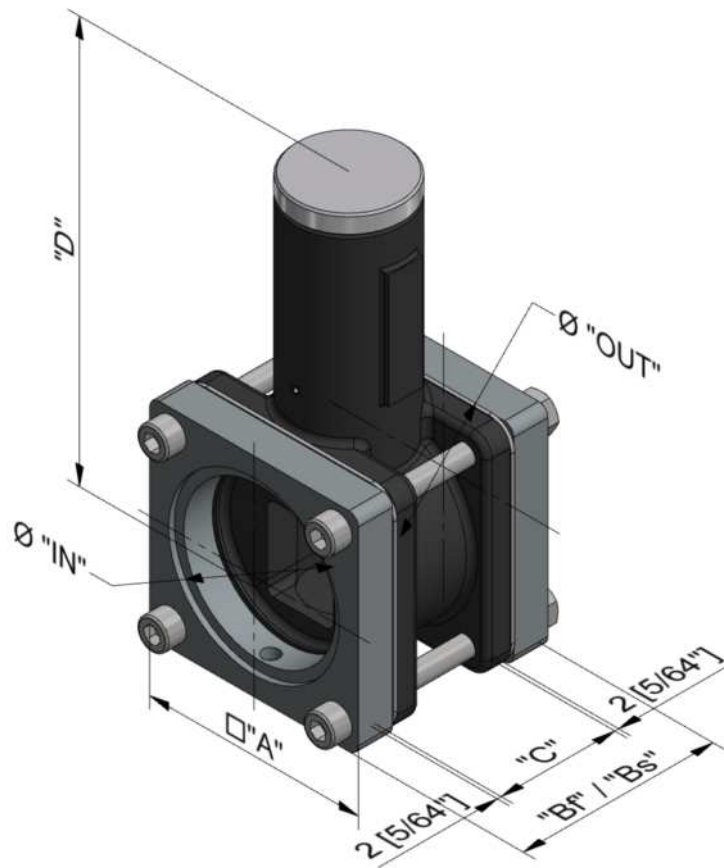

D1601I05

Model	Ø "IN"	Ø "OUT"	Ø "A"		"BF"		"Bs"		"C"		"D"		Mass	
	(*)	(*)	[mm]	[inch]	[mm]	[inch]	[mm]	[inch]	[mm]	[inch]	[mm]	[inch]	[Kg]	[lbs]
12GAF16	Rp 1.1/2"	Rp 2"	90	3.35/64	107.5	4.15/64	80	3.5/32	40	1.37/64	160	6.19/64	3.41	7.51
16GAF16	Rp 2"	Rp 2"	90	3.35/64	105	4.9/64	80	3.5/32	40	1.37/64	160	6.19/64	3.37	7.42
16GAF20	DN50	DN65	100	3.15/16	-	-	95	3.47/64	55	2.11/64	200	7.7/8	5.93	13.07
20GAF20	DN65	DN65	100	3.15/16	-	-	95	3.47/64	55	2.11/64	200	7.7/8	5.71	12.58
20GAF24	DN65	DN80	110	4.21/64	-	-	100	3.15/16	60	2.23/64	215	8.15/32	6.93	15.27
24GAF24	DN80	DN80	110	4.21/64	-	-	100	3.15/16	60	2.23/64	215	8.15/32	6.73	14.83
24GAF32	DN80	DN100	150	5.29/32	-	-	115	4.17/32	75	2.61/64	302	11.57/64	16.27	35.87
32GAF32	DN100	DN100	150	5.29/32	-	-	115	4.17/32	75	2.61/64	302	11.57/64	15.80	34.83

(*) NPT threads on request

ESA contacts



© 2020 ESA S.p.A. Company under the management and coordination of SIAD S.p.A.
All rights reserved.

The information contained herein is offered for use by technically qualified personnel at their discretion and risk without warranty of any kind.

We regularly update our data, for updated data please visit our web site www.esapyronics.com



ESA Italia (headquartes)

via E. Fermi 40, 24035 Curno (Bergamo), Italy
tel. +39.035.6227411 - esa@esacombustion.it

ESA Belgium

Zoning Industriel, 4ème rue, B-6040 Jumet, Belgium
tel +32.71.256970 - marketing@pyronics.be

ESA India

Plot No. J-17, MIDC, Bhosari, Pune, 411 026, India
tel. +91.(020).68197001 - esaindia@esapyronics.com

www.esapyronics.com