

MOTORIZED ADJUSTABLE PORT VALVES

VL-2R-CMAP SERIES

FEATURES

Features of the valve:

- | | |
|--|-----------|
| • Valve body (series 4/6/8 VL) | AVP |
| • Valve body (series 10/12/16/20/24/32 VL) | aluminium |
| • Primary regulation screw | brass |
| • Secondary regulation shaft | AISI303 |
| • Electric control support | iron |
| • Push rod | brass |
| • Max. operating pressure | 500 mbar |
| • Max fluid temperature | + 60°C |

Features of the electric control MOD. ECON-O:

- | | | |
|---|---------------------------------|----------------------------|
| • Voltage: | 24/115/230V +10%-15% | 50/60Hz |
| • Proportional control signal on request: | 0÷10V, 4÷20mA | (only for ECON-O 24V) |
| • Power consumption: | | 4 VA |
| • No. 2 auxiliary micro-switches: | | 5A/250 Vac |
| • Protection standard: | | IP54 |
| • Connections no. 2 cable entries: | | PG 13.5 |
| • Angle of rotation: | | 90° |
| • 90° rotation time | 7 to 120 s | (standard 60 s) |
| • Max. operating temperature: | | -10°C to +60°C |
| • Housing die: | | cast aluminium |
| • Shaft protection: | | 9.5 mm |
| • Potentiometers available: | 1.150 Ohm, 1.000 Ohm, 2.500 Ohm | (standard no. 1 1.000 Ohm) |
| • Weight: | | 2.5 Kg |
| • Mounting position: | | optional |



F1671/01

DESCRIPTION

The VL-2R-CMAP is a particular kind of modulating valve with micro-metric adjustable port. It's designed for air and gas flow regulation in low & medium pressure lines. The flow can be adjusted by operating on the primary regulation shaft with an electric control equipment (ECON-O series). A graduated index on the valve body identifies the OPEN/CLOSED position. The port of the valve can be adjusted by the secondary regulation screw. In this way, a more accurate flow regulation is possible. The cams & auxiliary end switches calibration has to be made after the installation and it's important to verify it on-site.

APPLICATION RANGE

- Valve for air and gas flow regulation. The port, hence the flow may be adjusted the need.
- Throttle valve with leak in FULL-CLOSED configuration (< 1%)

INSTALLATION

- The valves can be mounted in any position
- The valves must be mounted downstream any measuring device.
- The valve toughness guarantees long life in extreme conditions.
- The adjustable port VL-2R-CMAP valves are not designed for full tightness in closed position but only for regulation. Therefore it is advisable to mount safety devices downstream the valve in fuel gases feeding lines.



Headquarters
Esa S.r.l.
Via E. Fermi 40 I-24035 Curno (BG) - Italy
Tel. +39.035.6227411 - Fax +39.035.6227499
esa@esacombustion.it - www.esapyronics.com

International Sales
Pyronics International S.A./N.V.
Zoning Ind., 4ème rue B-6040 Jumet - Belgium
Tel +32.71.256970 - Fax +32.71.256979
marketing@pyronics.be

FLOW CHART

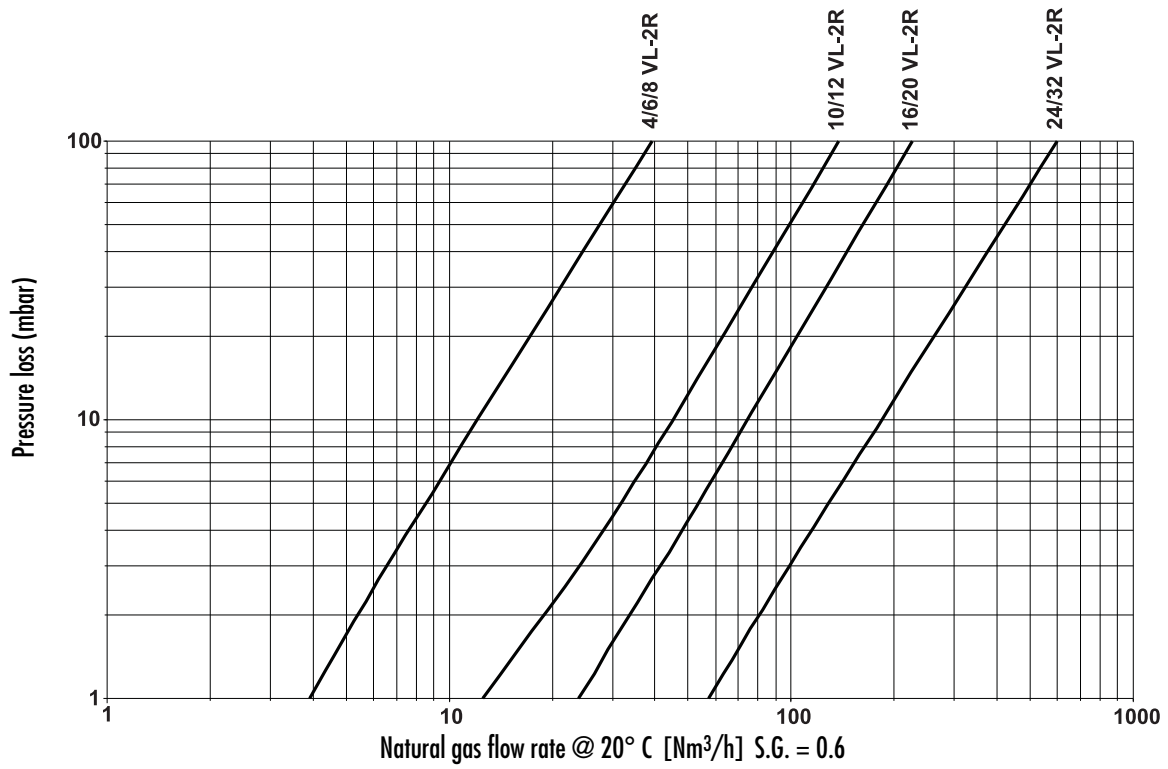

G167101

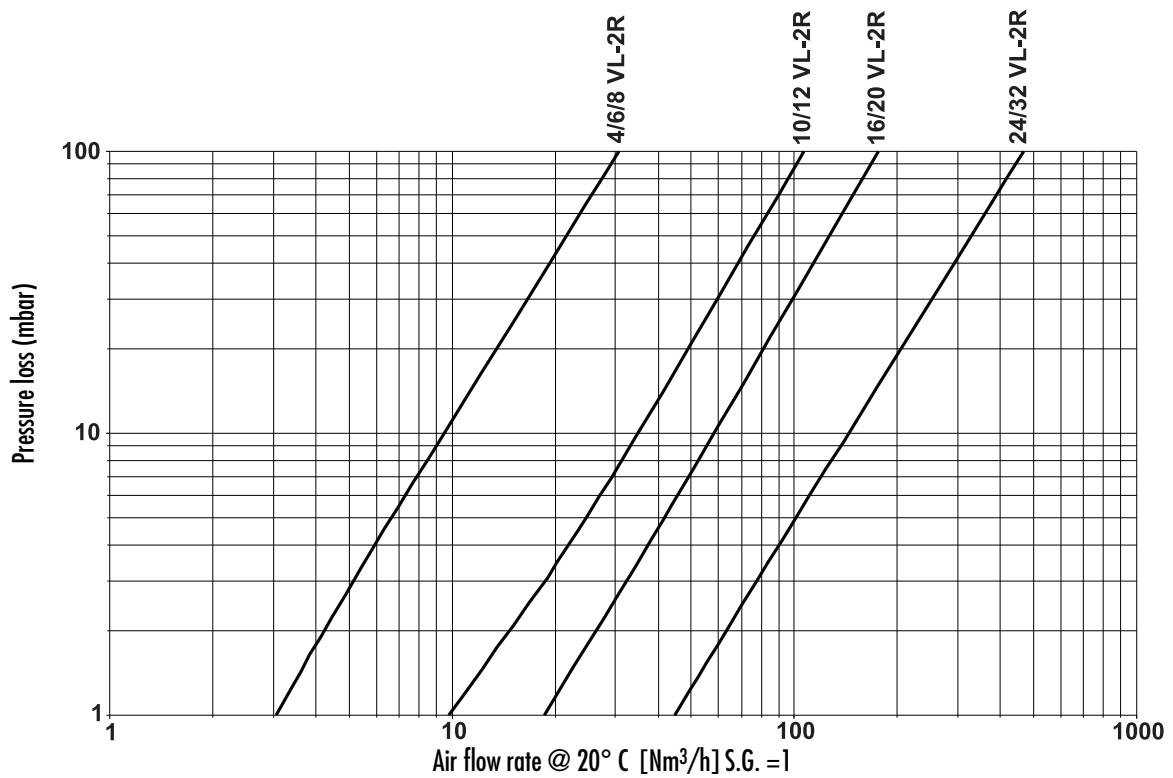

G167102

The capacities are referring to the shaft of the secondary regulation completely open.

DIMENSIONS

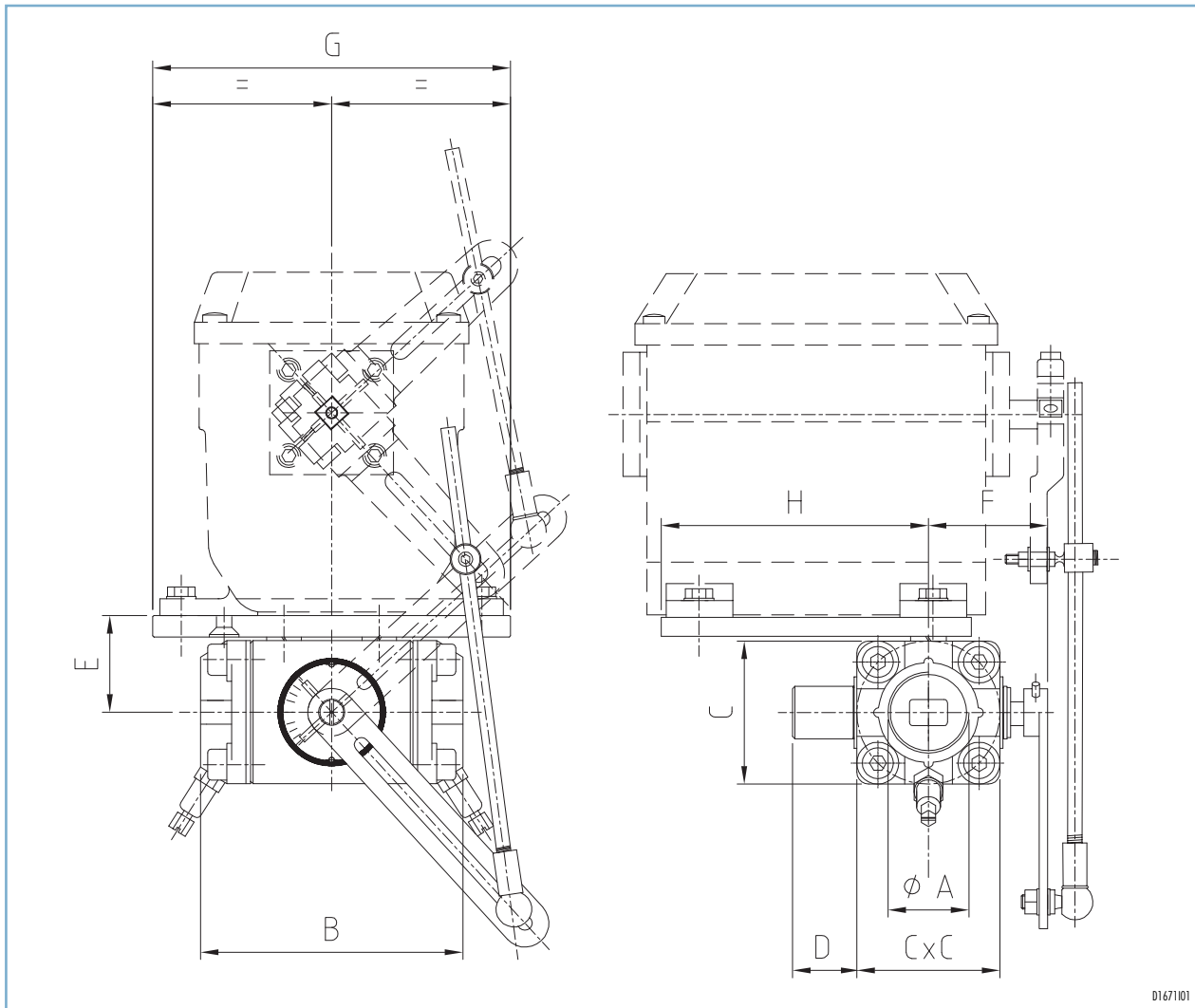

D167101

Model	ø A	B mm	C mm	D mm	E mm	F mm	G mm	H mm	Weight Kg
4 VL-2R-CMAP	Rp 1/2"	110	60	44	39	50	150	112	5.7
6 VL-2R-CMAP	Rp 3/4"	110	60	44	39	50	150	112	5.7
8 VL-2R-CMAP	Rp 1"	110	60	44	39	50	150	112	5.7
10 VL-2R-CMAP	Rp 1.1/4"	125	80	49	50	60	150	102	5.5
12 VL-2R-CMAP	Rp 1.1/2"	125	80	49	50	60	150	102	5.5
16 VL-2R-CMAP	Rp 2"	132	100	87	60	70	150	92	8.7
20 VL-2R-CMAP	DN65	108	100	87	62	70	150	92	8.9
24 VL-2R-CMAP	DN80	130	150	114	87	95	150	67	17.0
32 VL-2R-CMAP	DN100	130	150	114	87	95	150	67	16.0

DIMENSIONS (ECON-O)

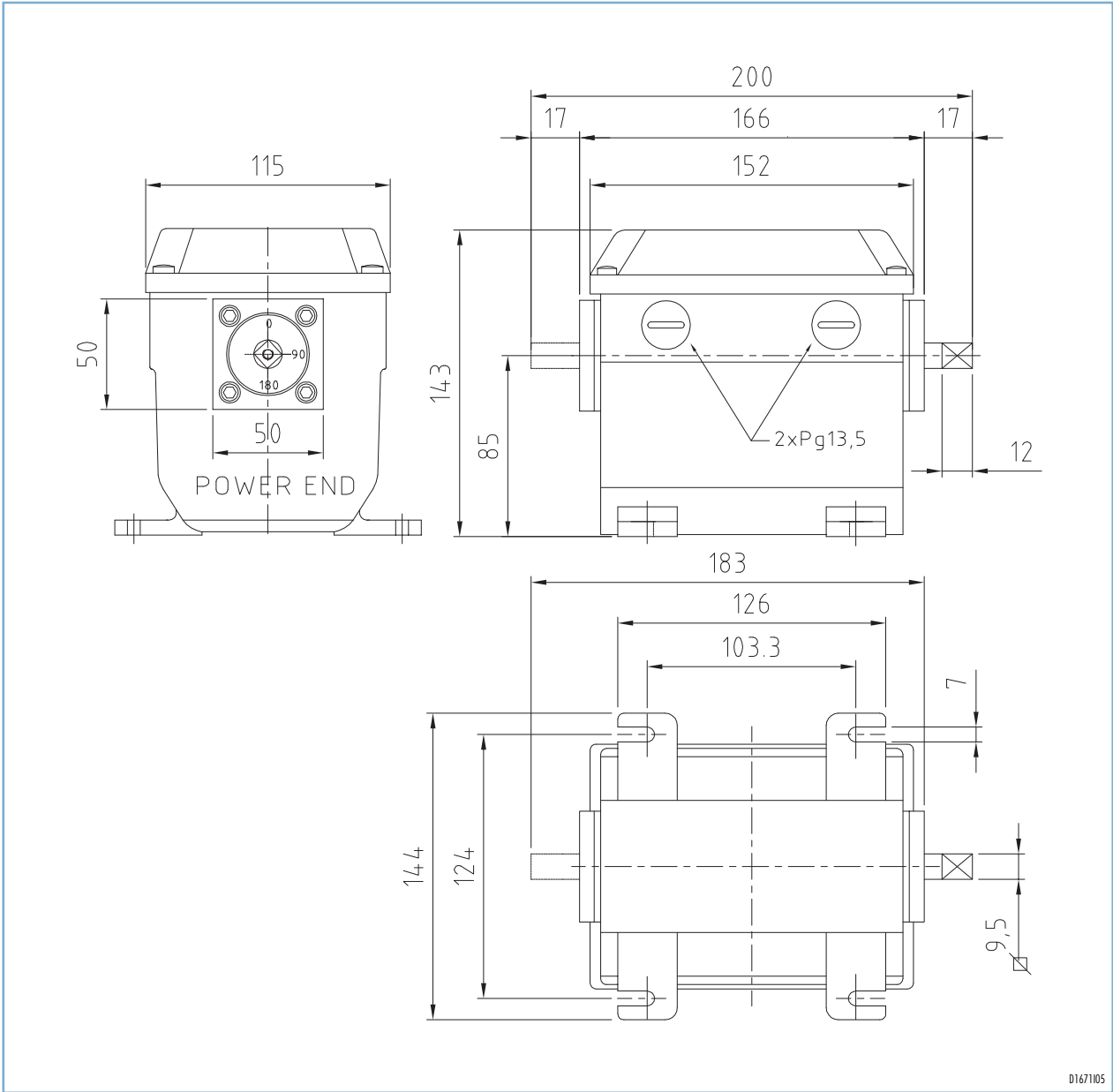

D167105

ELECTRICAL CONNECTIONS

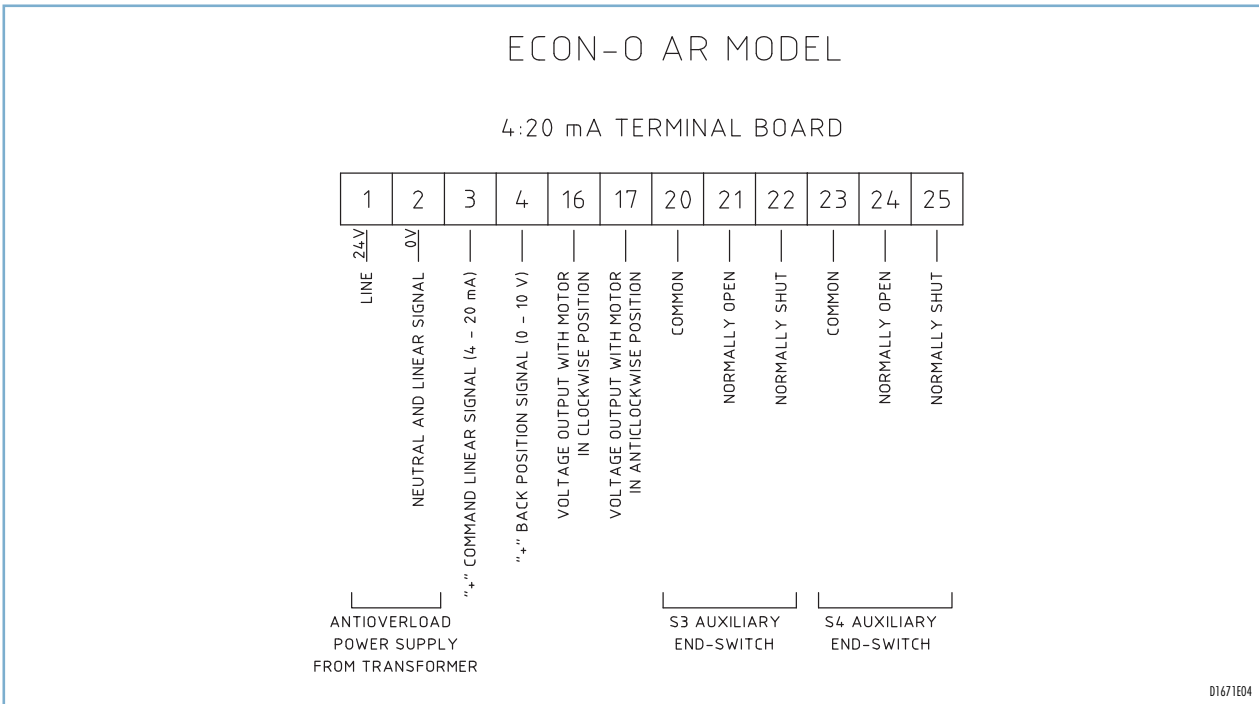
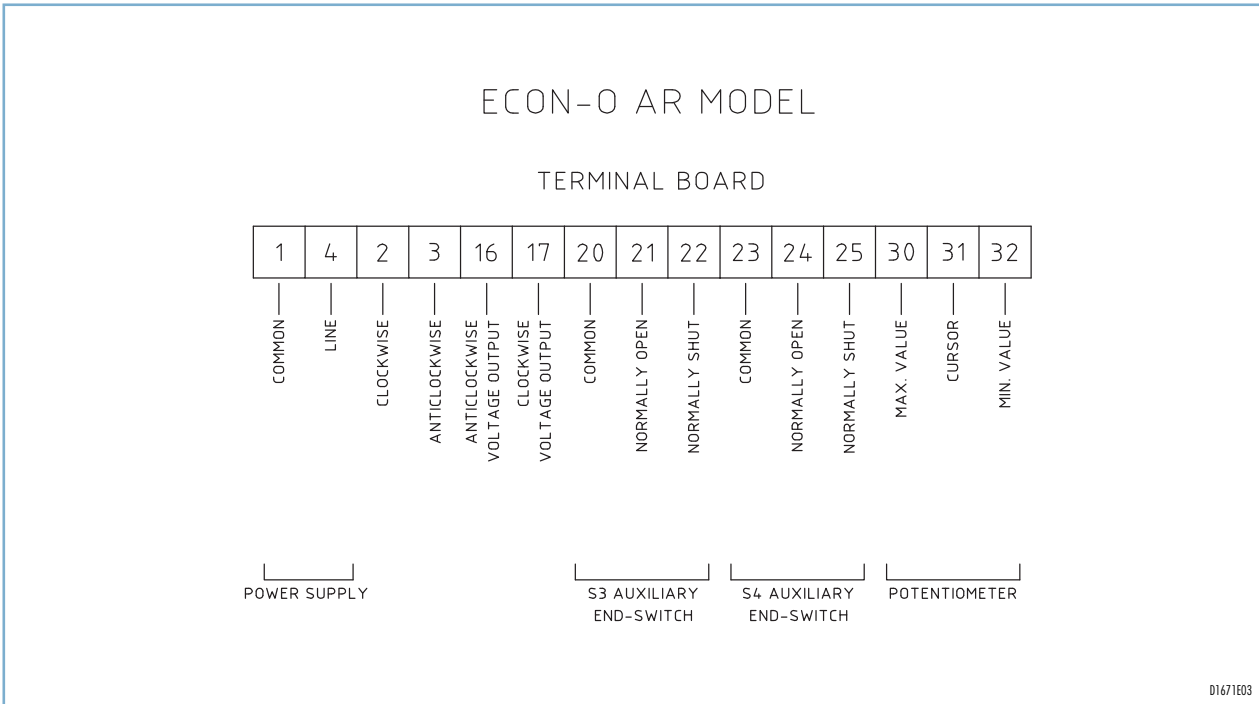

NOTE: Based on the company's policy aimed at a continuous improvement on product quality, ESA-PYRONICS reserves the right to bring changes to the technical characteristics of this device without previous notice. Our catalog updated to the latest version is available on our web site www.esapyronics.com and it is possible to download modified documents

WARNING: Operating a combustion system can be dangerous and cause harm to persons or damage to equipment. Every burner must be provided with safety devices that monitors the combustion. The installation, adjustment and maintenance operations should only be performed by trained and qualified personnel.