

*Electronics*

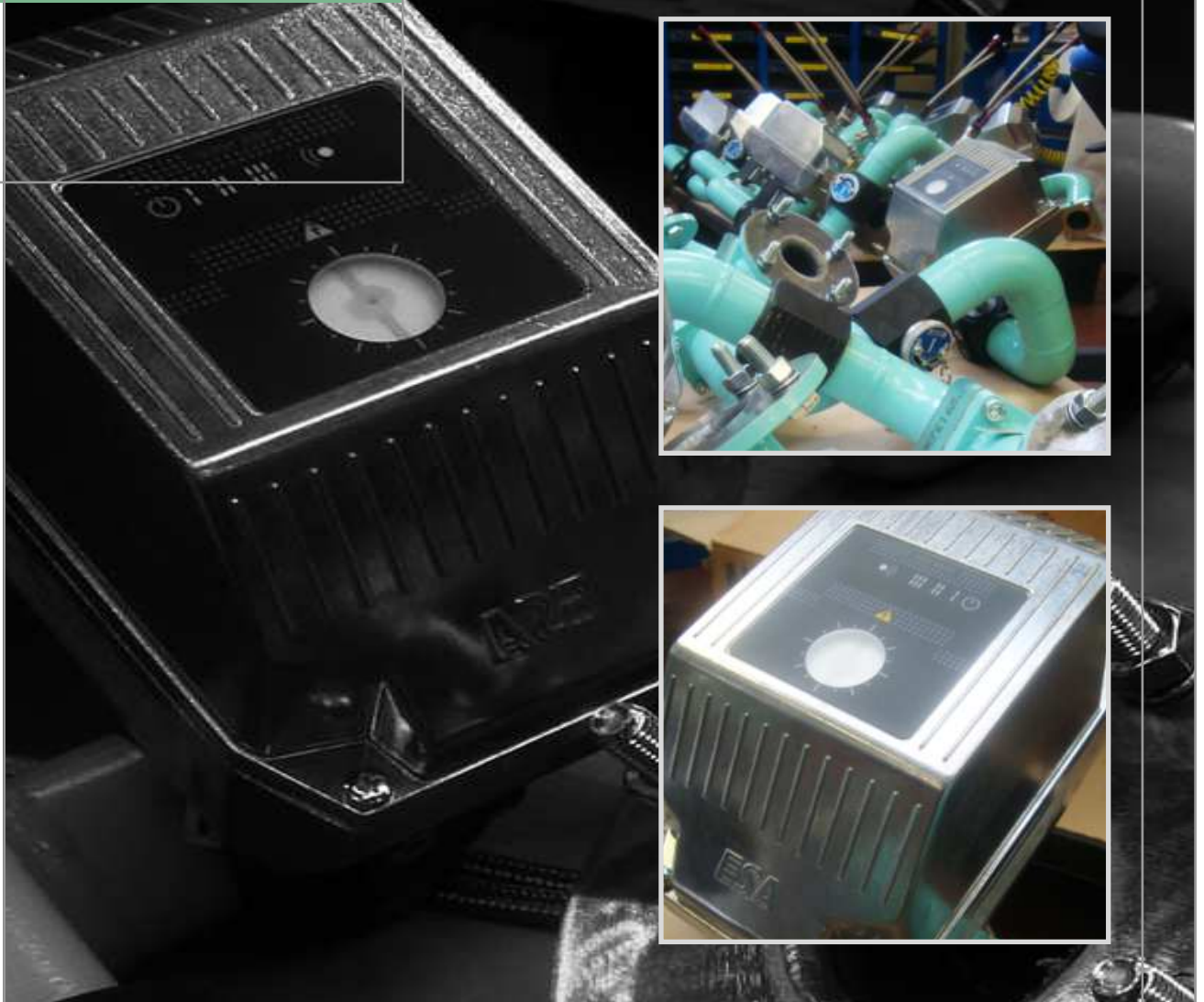

## Electric Servomotor

ESA SERIO TPF (E7301 rev. 01 - 27/05/2014)

## GENERAL WARNINGS:



■ All installation, maintenance, ignition and setting must be performed by qualified staff, respecting the norms present at the time and place of the installation.

■ To avoid damage to people and things, it is essential to observe all the points indicated in this handbook. The reported indications do not exonerate the Client/User from observing general or specific laws concerning accidents and environmental safeguarding.

■ The operator must wear proper DPI clothing (shoes, helmets...) and respect the general safety, prevention and precaution norms.

■ To avoid the risks of burns or high voltage electrocution, the operator must avoid all contact with the burner and its control devices during the ignition phase and while it is running at high temperatures.

■ All ordinary and extraordinary maintenance must be performed when the system is stopped.

■ To assure correct and safe use of the combustion plant, it is of extreme importance that the contents of this document be brought to the attention of and be meticulously observed by all personnel in charge of controlling and working the devices.

■ The functioning of a combustion plant can be dangerous and cause injuries to persons or damage to equipment. Every burner must be provided with certified combustion safety and supervision devices.

■ The burner must be installed correctly to prevent any type of accidental/undesired heat transmission from the flame to the operator or the equipment.

■ The performances indicated in this technical document regarding the range of products are a result of experimental tests carried out at ESA-PYRONICS. The tests have been performed using ignition systems, flame detectors and supervisors developed by ESA-PYRONICS. The respect of the above mentioned functioning conditions cannot be guaranteed if equipment, which is not present in the ESA-PYRONICS catalogue, is used.

## DISPOSAL:



To dispose of the product, abide by the local legislations regarding it.

## GENERAL NOTES:



■ In accordance to the internal policy of constant quality improvement, ESA-PYRONICS reserves the right to modify the technical characteristics of the present document at any time and without warning.

■ It is possible to download technical sheets which have been updated to the latest revision from the **www.esapyronics.com** website.

■ The products manufactured by ESA-PYRONICS have been created in conformity to the **UNI EN 746-2:2010** Norms: Equipment for industrial thermal process - Part 2: Safety requirements for combustion and the movement and treatment of combustible elements. This norm is in harmony with the Machine Directive **2006/42/CE**. It is certified that the products in question respect all the requirements prescribed by the above mentioned Norms and Directives.

■ Certified in conformity with the **UNI EN ISO 9001** Norm by DNV GL.

## CERTIFICATIONS:



ESA SERIO conforms to the European Directives: Low voltage directive **2014/35/UE**, Electromagnetic immunity **2014/30/UE**.



The products conform to the requests for the Euroasia market (Russia, Belarus and Kazakhstan).

## ASSISTANCE/CONTACTS:



### Headquarters:

Esa S.p.A.  
Via Enrico Fermi 40  
24035 Curno (BG) - Italy  
Tel +39.035.6227411  
Fax +39.035.6227499  
[esa@esacombustion.it](mailto:esa@esacombustion.it)

### International Sales:

Pyronics International s.a.  
Zoning Industriel, 4ème rue  
B-6040 Jumet - Belgium  
Tel +32.71.256970  
Fax +32.71.256979  
[marketing@pyronics.be](mailto:marketing@pyronics.be)

[www.esapyronics.com](http://www.esapyronics.com)

ESA SERIO TPF is a microprocessor controlled servomotor that is suitable for controlling air flow regulation valves that are set in predefined positions. The device controls the valve in three fixed positions: minimum, intermediate and maximum opening according to the incoming commands received. Detection and regulation of the three positions can take place via the internal limit switch or via external flow switches. The aluminum casing of the servomotor makes it particularly suitable for industrial applications, allowing the application in the immediate vicinity of the burner.

## APPLICATIONS

- Control of air valves for three-stage pulse controlled burners (OFF/MIN/MAX), with air valve capacity control with burner off.
- Control of air valves for double stage impulse controlled burners (OFF/MAX or MIN/MAX).
- Turn-on the burners to minimum power, pulse rate between minimum and maximum burner power, furnace prepurge or controlled cooling only with air.

## CHARACTERISTICS

- Command signal: digital OFF/ON
- Torque: 5Nm
- Rotation angle: 90°
- 90° rotation time: 12 sec
- Servomotor fixing holes: DIN ISO 5211 F07
- Valve command output shaft: diameter 8 mm
- Supply voltage: 24Vac, 115Vac or 230Vac +10÷-15%
- Power frequency: 45÷65 Hz
- Supply type: phase-to-neutral, not suitable for phase-to-phase
- Neutral type: is suitable both for systems with neutral to ground as well as systems with neutral not to ground.
- Absorption: 6 VA max
- Functioning temperature: 0÷60 °C
- Storage temperature: -20÷80 °C
- Local Auto/Man control station: included
- Digital input voltage: same as supply voltage
- Digital input absorption: max 5mA
- Limit position of overrun output tension (\*): equal supply voltage
- Maximum voltage applicable to auxiliary limit switches: 250Vac
- Maximum current of auxiliary limit switches: 1.5 A
- Instrument protection fuse: fast 250mA, replaceable
- Mass: 2.200 g
- Electric cable input: n°4 threaded inputs M20x1,5
- Protection degree: IP54 (for wiring use specific cable glands)
- Mounting position: any
- Work environment: not suitable for use in explosive or corrosive areas
- Container: Aluminium
- Dimensions: 198×119×143 mm



F7301103



F7301104

(\*) The overrun outputs are activated only for a few moments after reaching the respective limit positions.

## DESCRIPTION

ESA SERIO TPF is an intelligent electrical servomotor that controls the position of the flow regulation valve according to the input command combination. Depending on which signal is present, the device commands the opening or closing of the valve until reaching the position requested. The three fixed positions are controlled via two digital command inputs, where one establishes the intermediate opening and the other the maximum opening. In the absence of both, the servomotor commands the valve to its minimum opening.

The position detection to be achieved is via two digital inputs for status, one for the intermediate opening and the other for maximum opening.

The command digital inputs must be controlled by the control unit (burner control, temperature regulator etc.), instead the status digital inputs can be connected to the internal auxiliary limit switches or to the flow switches found on the piping of the air controlled.

On the upper panel ESA SERIO TPF has a visual indica-

tor and some signal leds: the first indicator indicated the valve opening whilst the leds inform the operator about the status of the servomotor and the type of command.

ESA SERIO TPF is designed for easy use by the user: the local control station coupled to the signaling LEDs allow easy pre-determination of the positions associated with the controls, as well as facilitate the regulation of the burners operated by the valve. The device allows three modes of operation: automatic, manual and settings, depending on the needs of the operator.

The actuator may be keyed directly to the valve, with a direct connection to the valve stem, or mounted on a support plate and connected to the valve stem via a system of slotted levers, rods and adjustable joints, so as to reduce the stroke of the valve while maintaining full stroke of the actuator for better calibration management according to the needs of the application.

ESA SERIO TPF is supplied in a robust aluminum housing already equipped with exit holes for the cables.

## DISPLAY AND LOCAL CONTROL SECTION



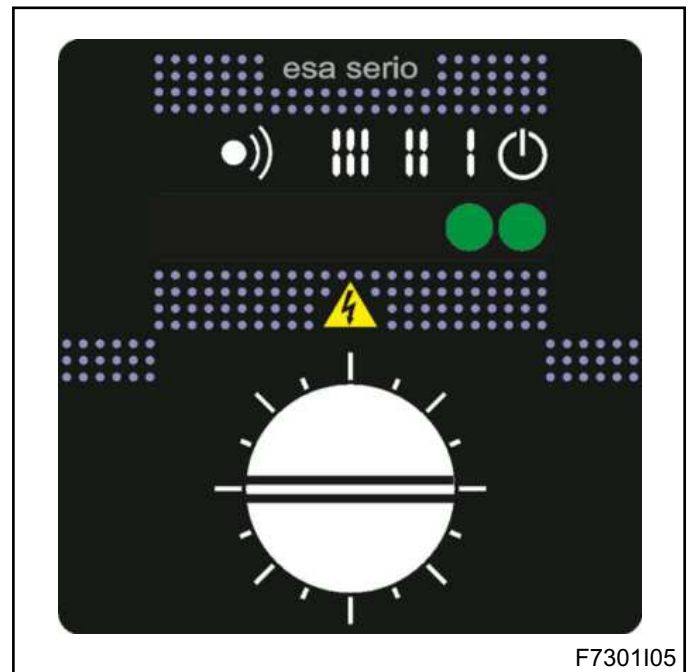

### DISPLAY SECTION

On the upper side of the cover the ESA SERIO TPF has a display section made up of a visual indicator and 4 indication leds. The visual indication, created by two black indicators on a white background is fixed onto the top of the valve command shaft, indicates the actual opening of the valve. Depending on whether the servomotor is mounted perpendicularly or longitudinally compared with the piping, it is possible to rotate the visual indicator so that the valve position is respected.

The four indication leds, one of which is related to the power and the others to the regulated positions, take on different behaviours according to the functioning mode that is selected by the operator. The distinction between the different modes is given by the supply led that changes its status from fixed on, slow blinking and fast blinking.





LED	STATUS	DESCRIPTION
<b>LED POWER</b> 	On (steady)	ESA SERIO TPF is in automatic mode and controls the valve position, between the three default settings, depending on the request from the control unit. The local control via the CMD switch has no effect.
	Slow blinking	ESA SERIO TPF is in Manual mode and controls the position of the valve between the three default settings, depending on the application by the operator via the CMD switch. The commands coming from the control unit have no effect.
	Fast blinking	ESA SERIO TPF is in setting mode to allow the operator to adjust the three default settings. By acting on the CMD selector, the operator can command the valve to open or close as he wishes, for the entire available stroke (0°+90°), being able to stop it in intermediate positions. The commands coming from control units have no effect, and neither are the default settings respected. In this mode the blinking alternates with the leds "I".
<b>LED1</b> 	On (steady)	In the Automatic and Manual modes it indicates that ESA SERIO TPF is in the minimum regulated opening positions related to the cam S1 (0°). This condition is not present in the Setting mode.
	Slow blinking	In Automatic and Manual mode it indicates that ESA SERIO TPF is reaching the minimum opening as a result of a change of control. If the previous position was the intermediate opening, the LED may blink for a few seconds after the motor has stopped. This condition is not present in the Setting mode.
	Fast blinking	Indication that ESA SERIO TPF is in setting mode, and in this mode the flashing alternates with that of the power supply LED.
<b>LED2</b> 	On (steady)	In Automatic and Manual mode indicates that ESA SERIO TPF is in the condition of intermediate opening default. If the default position are governed by the internal limit switches, this position corresponds to the set with the S3 cams (eg 20°). In setting mode indicates that the signal corresponding to the digital intermediate position is present.
	Slow blinking	In Automatic and Manual mode it indicates that ESA SERIO TPF is reaching the intermediate open default as a result of a change of control. Setting mode indicates that the signal corresponding to the digital intermediate position is absent.
	Fast blinking	Unexpected condition
<b>LED3</b> 	On (steady)	In Automatic and Manual mode it indicates that ESA SERIO TPF is in the maximum open default condition. If the default position are controlled by the internal limit switches, this position corresponds to the set with the cam S4 (eg 70 °) Setting mode indicates that the signal corresponding to the maximum position is present.
	Slow blinking	In Automatic and Manual mode it indicates that ESA SERIO TPF is reaching the maximum default opening as a result of a change of control. In setting mode indicates that the digital signal corresponding to the maximum position is absent.
	Fast blinking	Unexpected condition

## LOCAL COMMAND

Inside ESA SERIO TPF there is the local control consisting of two selectors that are accessible by removing the top cover. The local control station allows the adjustment

of the stroke of the valve as well as the simulation of the commands from the control system, so as to facilitate the operations of valve or burner setting.

SELECTOR	POSITION	DESCRIPTION
<b>MOD</b>	0	ESA SERIO TPF is operated in Automatic mode, so it will comply with the requests from the control unit, and local control via the CMD switch has no effect.
	1	ESA SERIO TPF is commanded into Setting mode, for which it will comply with the requests from the selector CMD, while the commands coming from the control unit have no effect.
	2	ESA SERIO TPF is controlled into Manual mode, so it will comply with the requests from the selector CMD, while the commands coming from the control unit have no effect.
<b>CMD</b>	0	In Automatic mode this selection has no effect.  In Manual mode it requires positioning of the valve at the minimum default opening.  In Setting mode it allows the operator to stop the valve in the position reached, without it being a default position.
	1	In Automatic mode this selection has no effect.  In Manual mode it requires positioning of the valve at intermediate default opening (es. 20°).  In Setting mode it allows the operator to close the valve, also in steps, for obtaining the opening percentage required for the burner regulation or definition of the intermediate positions. The closing command is active throughout the available stroke (90 ° to 0°).
	2	In Automatic mode this selection has no effect.  In Manual mode it requires positioning of the valve at maximum default opening (es 70°).  In Setting mode it allows the operator to open the valve, also in steps, for obtaining the opening percentage required for the burner regulation or definition of the intermediate positions. The opening command is active throughout the available stroke (0° to 90°).

## FUNCTIONING

Depending on the mode selected, ESA SERIO TPF changes its behaviour.

### AUTOMATIC MODE

Automatic mode is also defined as regime mode, as it is the working mode of the ESA SERIO TPF servomotor during the autonomous operation of the combustion plant.

In automatic mode ESA SERIO TPF receives from the control unit (burner control unit, temperature regulator-etc.), the commands via D1 and D2 digital inputs. When only the first input (D1) is present, the valve is forced into

the intermediate opening position; when instead only the second input (D2) is present or if they are both present (D1+D2), the valve is taken to the maximum preselected opening. The absence of both the commands involves the closing of the valve until minimum opening. This control logic allows to switch on the burner at low potential, and then carry out pulse commands between minimum and maximum potential besides closing the valve when the burner must remain off.

Being able to directly control the maximum opening only with a digital input, you can carry out prepurge phases or controlled cooling.

DIGITAL COMMAND 1	DIGITAL COMMAND 2	VALVE POSITION
OFF	OFF	ESA SERIO TPF commands the valve in the minimum opening position or closed valve, to reduce the air intake with burner off.
ON	OFF	ESA SERIO TPF commands the valve in the position of intermediate opening, to ensure the minimum power of the ignited burner.
ON	ON	ESA SERIO TPF commands the valve in the position of maximum opening, to ensure the maximum power of the ignited burner.
OFF	ON	ESA SERIO TPF commands the valve in the position of maximum opening for prepurge or controlled cooling. In this case the burner is turned off (OFF D1).

ESA SERIO TPF detects the default positions (internal limit switch, external flowswitch etc) via the D3 and D4 digital inputs. The D3 digital input is related to the intermediate opening (e.g. 20°), whilst the D4 digital input is related to the maximum default input (e.g. 70°); accordingly in this mode, the maximum opening is the default corresponding to the input D4. In Automatic mode the power supply led is on (steady), whilst the leds regarding the command received and the actual position are either on or blinking until ESA SERIO TPF reaches the requested position.

### MANUAL MODE

The Manual mode is used during the burner regulation phase because it allows the operator to simulate automatic functioning. In this way it is possible to regulate each air flow or balance the valves in zones with multiple burner systems using one blower. Furthermore this function is useful during burner combustion regulation eliminating remote control system interactions. In Manual mode, with the selector CMD, ESA SERIO TPF replaces the commands from the remote control unit: the selector has three stable positions corresponding to the required minimum, intermediate and maximum openings. In this way it determines the command of the valve in the three default positions. In this mode ESA SERIO TPF detects the default positions always once again via the D3 and D4 digital inputs, as already happens in the automatic mode.

In Manual mode the power supply led blinks slowly, whilst the leds regarding the positions according to the command received and the actual position, are on (steady) or blinking until ESA SERIO TPF reaches the requested position.

### SETTING MODE

Setting mode allows regulation of the default positions, controlled then in Automatic and Manual mode. In particular it is possible to associate a default position of the valve at the D3 digital input and another at the D4 digital input, respectively for the intermediate opening position and the maximum opening position. The minimum opening position corresponds to the closed valve that allows a slight passage of air, is set in the factory. In Setting mode ESA SERIO TPF allows the operator to move the valve for the entire available stroke: activating the CMD selector it is possible to close, open or stop the valve at any point of the stroke. The valve stroke regulated by the manufacturer (0°÷90°) is limited by the internal limit switches, activated respectively by the S1 (0°) and S2 (90°) cams. In Setting mode ESA SERIO TPF alternately activates the power supply leds and LED 1 that are blinking rapidly, a part from visualizing the status of the digital inputs D3 and D4 switching on LED2 and LED3 respectively. These last two are on steady when the related inputs are present, or else they are blinking without inputs.

**EXAMPLE OF APPLICATION 1 - ESA SERIO TPF**

ESA SERIO TPF actuator receives the commands from the control unit (control unit for burner, temperature regulator etc) via the D1 and D2 digital inputs. In the example, the commands come from the burner control unit but could also come directly from the furnace control unit. ESA SERIO TPF detects the positions that are pre-esta-

blished by the internal limit switches via the D3 and D4 inputs. In this application the intermediate and maximum opening positions are regulated by acting on the internal limit switches S3 and S4 resulting unavailable for other functions.

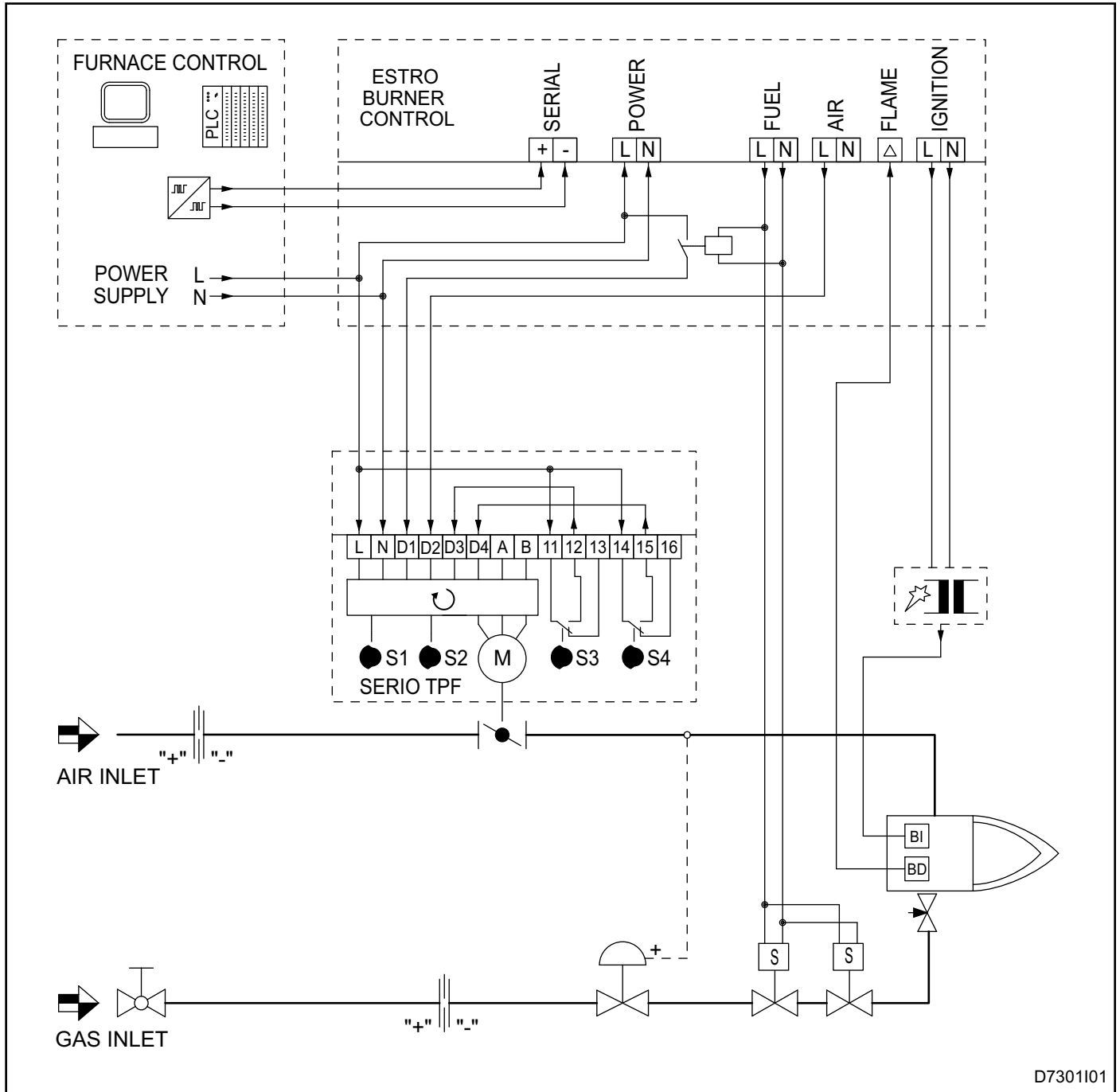

D7301101



**EXAMPLE OF APPLICATION 2 - ESA SERIO TPF**

The ESA SERIO TPF receives the commands from the control unit (control unit for burner, temperature regulator etc) via the D1 and D2 digital inputs. In the example, the commands come from the burner control unit but could also come directly from the furnace control unit. The device detects the positions that are pre-established by the

external flow switches via the D3 and D4 inputs, while the internal S3 and S4 limit switches remain available for possible remote indications. In this application the intermediate and maximum opening position is regulated by setting the F1 and F2 flow switches.

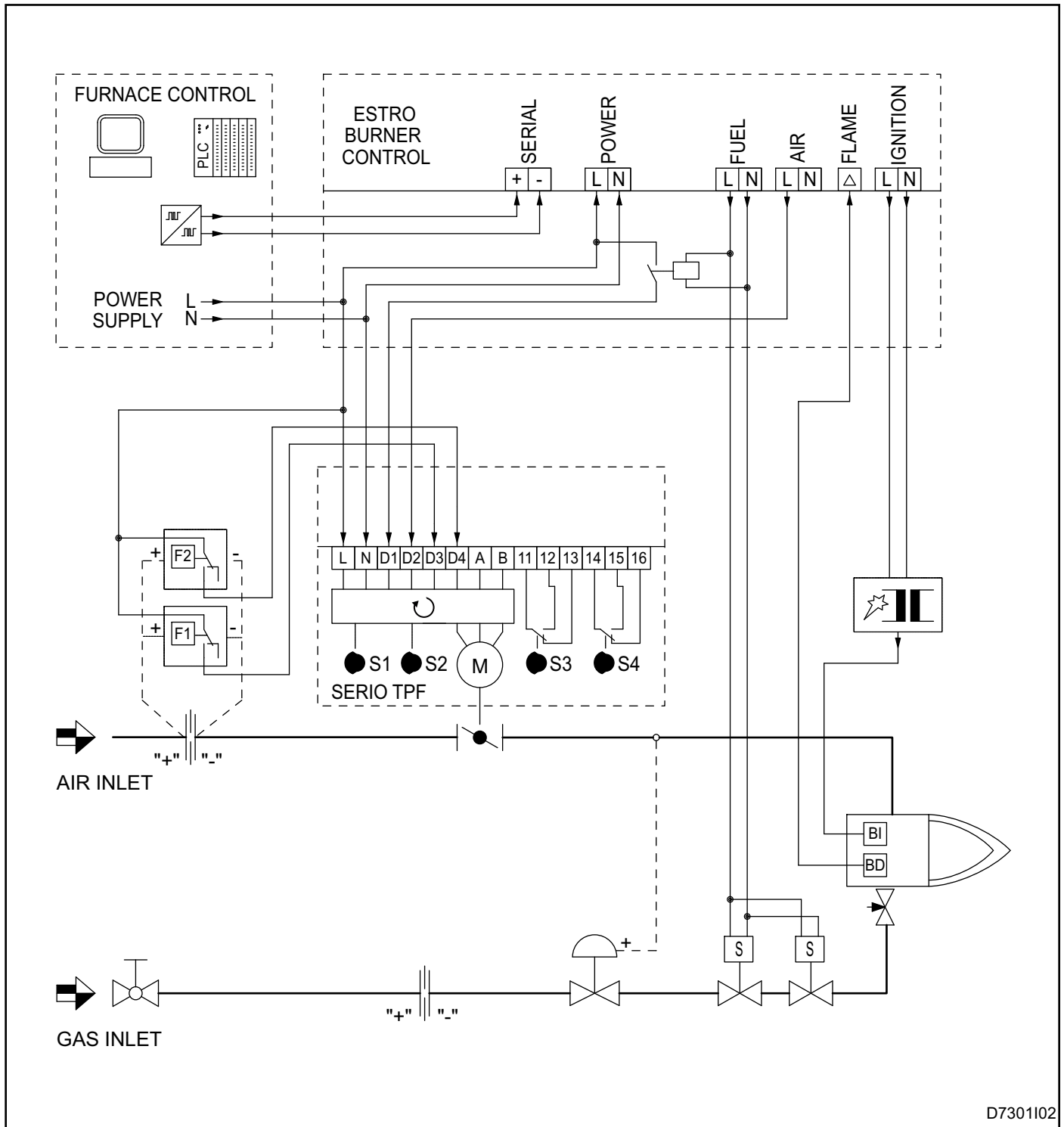

D7301102

## WARNINGS

For correct use of the servomotor, follow the warnings below:

■ When choosing the model, the torque, supply voltage and type of control must respond to the application. Before installing the device, make sure that the features conform with the definition.

■ ESA SERIO TPF is meant to be electrically connected in a permanent and fixed manner. The reverse/neutral connection may compromise the safety of the system. Do not use different phases between the various voltage inputs and do not apply voltages of the output terminals.

■ When the commands of the device come from the burner control unit, they cannot be connected together with safety solenoid valves, to avoid affecting the functions of the latter. In such cases, control the ESA SERIO TPF commands via outputs or uncoupling devices (expansion boards, relays).

■ Check the correct installation and connection after installation. Before applying power to the servomotor ensure that the voltage, frequency and control signals are correct. Ensure that users do not have an absorption higher than the maximum output contacts.

■ ESA SERIO TPF moves the valve only in the presence of supply voltage, so in case there is no power supply, the valve remains stationary in its last position.

■ Do not manually rotate the actuator shaft by forcing with the lever or tools to avoid damaging the internal reducer. Also to avoid breaking the internal reducer, make sure that there is nothing obstructing the valve rotation or mechanical stops at the end of the stroke (e.g. closing with mechanical stop).

■ Operate on the actuator and the devices connected in absence of power supply, except when using the local control station. At the end of each local operation, be sure to restore the operation in Automatic mode.

■ ESA SERIO TPF can be keyed on the valve with a direct connection to its stem, or mounted on a support plate and connected to the valve stem with rods and intermediate joints. For the connection between the output shaft of the actuator and the valve stem, use the specific articles (e.g. space levers and return joints).

■ In case of malfunctioning SERIO TPF must be sent to the manufacturer for repair. Any modifications or repairs made by a third party automatically void the warranty and compromise the security of the application.

■ ESA SERIO TPF is a device used for the control of the regulating valves. It does not deal with the security organs nor is it part of the protection system (according to EN746-2), for which there are special instruments.

## INSTALLATION

For correct installation follow the instructions below:

### MOUNTING

**1** - The installation must be performed by qualified personnel in compliance with the regulations in force at the time and place of installation.

**2** - Avoid placing ESA SERIO TPF near strong magnetic fields or electrical conditions and make sure it is not exposed to direct radiation from heat sources or in contact with combustion products, liquids, solvents or corrosive gases.

**3** - ESA SERIO TPF can be installed in any position. Do not limit in any way the area surrounding the actuator, but ensure adequate ventilation space to prevent overheating of the device, in addition to making adjustment operations easier.

**4** - Prior to mechanically mounting and connecting the actuator to the valve, by manually intervening on the valve stem verify that it is free to move through an angle greater than the adjustment range (0° to 90°). Ideally, the butterfly valve may turn on itself. At the end place the valve in the closing position, bearing in mind that ESA SERIO TPF controls the opening of the valve in anticlockwise direction and comes from the factory in the closed position (0°).

**5** - Interpose the specific spacers and connections of the shaft, after which attach the actuator to the valve by means of special bolts using the fixing holes in the lower part of the actuator. Using proper tools, progressively tighten the bolts in a crisscross pattern and avoid over-tightening.

**6** - ESA SERIO TPF is set for longitudinal mounting with the pipe. If the servomotor must be mounted transversely, at the end of the assembly it is necessary to rotate the internal position indicator, aligning it with the actual position of the valve disc.

### ELECTRICAL CONNECTION

**1** - For the passage of electric cables use the inputs already prepared in the actuator, without making further holes in the case. Install cable glands or gland sheaths to ensure a level of protection equal to or not less than IP40. For systems used in open air the degree of protection shall be equal to IP54. The degree of protection can also be provided by the container in which the device is inserted.

**2** - Verify that the actuator is compatible with the control system, for both the supply voltage as well as type of command.

**3** - If the power system is phase-to-phase type, you must install an isolation transformer with the connection of one end of the secondary winding referenced to ground.

**4** - During the electrical connection refer to the technical documentation, respecting the polarity between phase and neutral. The terminals for the electrical connections are screw type and can accept wires with sections from 0.5 to 2.5mm<sup>2</sup> and the choice of conductors and their location must be suitable for the application.

**5** - Adequately tighten the wires into the terminals to prevent malfunctioning or overheating which can lead to dangerous conditions. Numbering and the use of appropriate terminals on conductors is highly recommended.

**6** - Always make sure the protective earth is connected to the appropriate terminals and to all metallic frames using appropriate conductors. Failure to connect the device to the protective earth, causes a dangerous condition for the operator. For the connection of conductors of protective earth use the screw provided in the base of the device.

**7** - After connection, make sure that the wires do not interfere with the gears inside the servo motor. Close the cover, checking the proper positioning of the gasket and that the wires do not remain pressed between the cover and housing.

## REGULATION - SETTING

The indications in the following chapter must be carried out by qualified expert technicians or qualified staff. During the regulation phase monitor the flow of the pipeline through flow meters (orifice plate, differential pressure gauges, etc ...). Regulation and setting of the ESA SERIO TPF since it commands the valve in the default position, is to define the minimum, intermediate and maximum opening of the actual valve. Minimum opening must guarantee minimum air flow to keep the burner elements cooled when it is off. The intermediate opening must allow air flow which corresponds to the minimum burner power, while the maximum opening must correspond to the maximum burner power. The maximum position does not necessarily correspond to the fully opened valve (90°).

ESA SERIO TPF is set from the factory with the stroke from the valve closed to the valve open (0° to 90°), allowed by the action of internal limit switches actuated by the cams S1 (0°) and S2 (90°). The minimum opening position corresponding to closed valve (S1), should be adjusted only if the leakage of the butterfly valve is not sufficient to ensure the cooling of the burner when it is off; while the position of the fully opened valve (S2) should not be adjusted. If ESA SERIO TPF is not directly coupled to the valve but connected through a system of slotted levers, it is recommended to adjust the minimum opening via levers rather than acting on the internal switch S1. The adjustment of the position of the intermediate and maximum opening is done by acting on the elements respectively trigger the status inputs, such as internal limit switches, external flow switches or other elements. Even in this case, if the servomotor is connected via a system of slotted levers, it is suggested to adjust the maximum opening through slotted levers so as to reduce the stroke of the valve while maintaining the entire stroke of the servomotor, optimizing the regulation.

**1** - Open the actuator cover to get access to the local command station. Place the MOD switch in position 1 to activate the "Setting mode".

**2** - Set the switch CMD in position 1, so that the valve is forced into the closing position or minimum opening. Evaluate if the flow of air due to leakage of the valve is sufficient to cool the burner. If not, anticipate the intervention of the cam S1, so that the valve does not close completely.

**3** - To adjust the cam S1 act on the adjustment screw cam S1 so that the movable part of the cam slightly rotates clockwise, seen from the position indicator located above the cams. Then command the valve to open, positioning the selector CMD in the 2-position and after a few degrees, command the closing of the valve (CMD=1) verifying the effect of the regulation. If anticipating the intervention it is not sufficient, repeat the same steps by rotating the cam in a clockwise direction, while if it is excessive, the

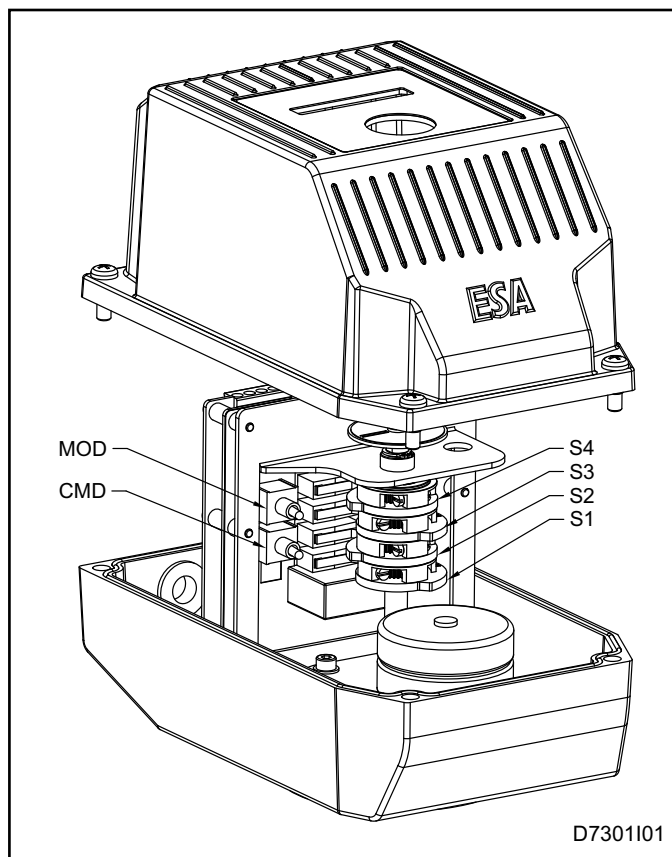

cam must be rotated anticlockwise.

**4** - Once the adjustment of the minimum opening has been completed, you can switch to the intermediate position. Control the valve opening (CMD=2) and then stop (CMD=0) as soon as you reach the air flow on the minimum power of the burner.

**5** - Adjust the element that activates the digital input D3, checking the status of the LED2: with proper or higher flow rate it must be lit steady, while with lower flow rate it must be flashing. Where the status inputs D3 and D4 are driven by internal limit switches, act on the cam S3 to adjust the intermediate opening.

**6** - After adjusting the intermediate position you switch to the maximum position. Further control the valve opening and then stop it as soon as it reaches the air flow on the maximum power of the burner.

**7** - Adjust the element that activates the digital input D4, checking the status of LED 3: with proper or higher flow rate it must be lit, while with lower flow rate it must be flashing. Where the status inputs D3 and D4 are driven by internal limit switches, act on the cam S4 for the adjustment of the intermediate opening.

**8** - Upon completion of this adjustment, set the MOD switch to position 2, in order to activate the "Manual"

## SETTING REGULATION

mode, to verify the accuracy of the adjustment made and correct it if necessary.

**9** - Set the CMD switch to the 0 position, so that the valve is forced to the minimum opening position, checking that the adjusted position is not changed.

**10** - Set the CMD switch in position 1, so that the valve is forced into the intermediate open position. Verify that the flow is correct, repeat the above adjustment if necessary.

**11** - Set the CMD switch in position 2, so that the valve is forced in the position of maximum opening. Verify that the flow is correct, repeat the above adjustment if necessary.

**12** - After the calibration of the default positions, place the MOD switch in position 0, in order to activate the "Automatic" mode, making sure that the commands from the control system are met by the actuator. At the end close the cover, checking the correct positioning of the gasket and verify that the conductors do not remain pressed between the cover and the case.

The ESA SERIO TPF actuators are supplied from the factory predisposed to rotate from 0° to 90°, with the auxiliary switches S3 and S4, respectively, adjusted to 20° and 70°.

## GENERAL MAINTENANCE PLAN

CHECK	TYPE	ADVISED TIME	OPERATION
Actuator closing	O	periodic	Make sure that the actuator is always closed to prevent dirt, dust and moisture from entering and damaging the device.
Connection cable integrity	O	Half-yearly	Verify the integrity of the outer insulation and the absence of abrasion or signs of overheating of the conductors.
Actuator stroke	O/E	Half-yearly	Verify that there is nothing impeding the valve movement.
Actuator regulation	O/E	yearly	Check the flow control performed by the actuator.
Actuator feedback	O/E	yearly	Verify that the commands from the control system are properly met.
Bolt tightening	O/E	yearly	Reduce to half-yearly basis in applications with vibration.
Actuator replacement	E	/	Replacement is necessary if the device is no longer functioning.

### NOTES:

Key: O = ordinary / E = extraordinary

The internal reducer unit is immersed in grease and does not require lubrication.



## ORDINARY MAINTENANCE

For proper maintenance of ESA SERIO TPF servo motors, carefully follow the instructions below. Before performing maneuvers with the system on, ensure that the process and operator safety are not compromised and possibly inspect with the system off.

### ACTUATORS CLOSING CHECK

■ The closure of the actuator is fundamental for its correct functioning as it avoids the entry of agents that could damage the control board or the internal reducer. Check that the cover adheres to the base so that the gasket tightness is efficient. If there is dirt on the inside, first disconnect the electric supply from the device and then eliminate the dirt by blowing with compressed air. Do not use any mechanical means for this operation.

### CABLE INTEGRITY CHECK

■ The integrity of the electric cables can be checked visually. If it is necessary to work on the cables for inspection, if not completely visible, disconnect the power to the device before performing any type of operation. Before replacing the actuator, make sure that it is indeed the actuator causing the malfunctioning.

### ACTUATOR STROKE

■ The check that there is nothing impeding the valve

movement takes place by running a complete excursion, visually checking that there is no friction nor limitations of the stroke. If the valve controlled by the actuator is an air or fume shut-off valve, switch the connected burner off before performing the operation.

### ACTUATOR REGULATION

■ Inspection is carried out with burners off but with air flow present in the pipe. Check that the flow regulation done by the servo motor is correct. If necessary repeat all the steps indicated in the "REGULATION – SETTING" section.

### ACTUATOR FEEDBACK

■ Actuator check is carried out with burners off and can be done with or without flow. Check that the commands sent by the control system are carried out correctly by the actuator. If necessary repeat all the steps indicated in the "REGULATION - SETTING" section.

### BOLT TIGHTENING

■ Bolt tightening check applies to the valve mounting bolts placed in the bottom part and for the connecting bolts of the valve stem when slotted levers are used.

## EXTRAORDINARY MAINTENANCE

For proper maintenance of ESA SERIO TPF servo motors, strictly follow the instructions to be carried out with the system turned off.

### ACTUATOR REPLACEMENT

**1 -** Make sure that the actuator is indeed the cause for improper operation or malfunctioning and that you have an identical spare actuator to replace the faulty one, checking the data on the identity label.

**2 -** Disconnect electric power, remove the cover of the actuator and then disconnect the electric connection from the terminal. During this phase it is important to have the conductors numbered to avoid problems during the reconnecting phase, extract the conductors from the case being careful not to damage them.

**3 -** With valve connections via slotted levers, release the slotted lever from the actuator shaft without loosening the joints so as to make regulation easier afterwards (actuator pin position constant). This precaution is not valid with actuators keyed directly by the valve.

**4 -** Remove the bolt securing the actuator to the mounting plate or the valve and remove it. For actuators that are keyed directly to the valve one must be careful of the elements that transmit motion interconnected between the drive shaft and the valve stem.

**5 -** Attach the new actuator to the valve, having interposed elements for transmission of motion to the valve stem. For servo motors fixed on the support plate, slotted levers for controlling the valve stem will be connected after mounting the actuator.

**6 -** Put the wires into the actuator housing through the special holes and restore the connections to the terminal by referring to the wiring diagram.

**7 -** Verify that the commands sent from the control system are performed by the actuator. Repeat all the steps listed in the "REGULATION AND SETTING" section.

**ESA SERIO TPF ELECTRIC CONNECTIONS**

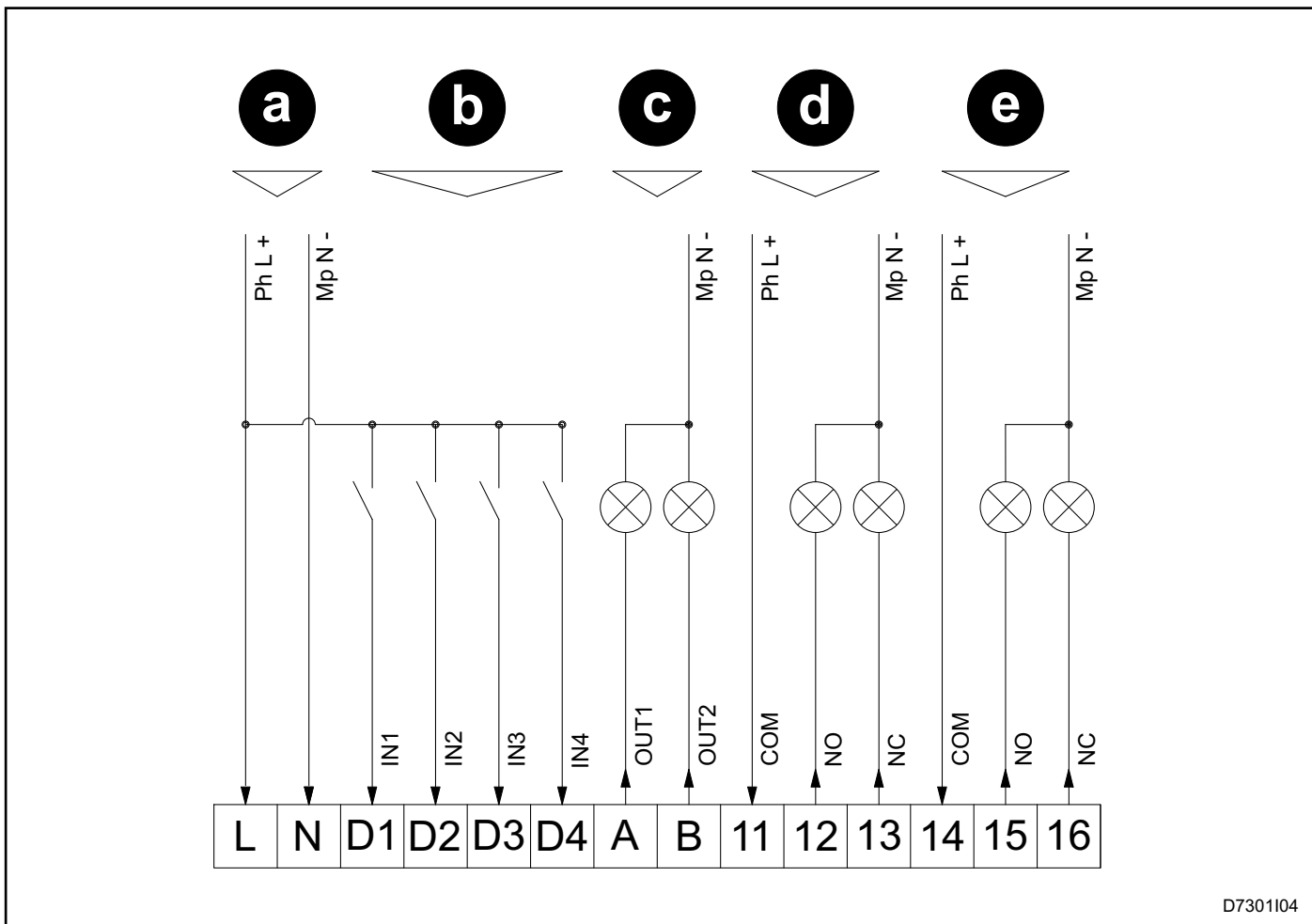

D7301104

Pos.	Description	Pos.	Description
a	Power supply	d	S3 outputs auxiliary limit switch
b	Digital inputs for control and status	e	S4 outputs auxiliary limit switch
c	Overrun outputs or limit positions reached (*)		

**TERMINAL CONNECTOR**

Pos.	Description	Pos.	Description
L	Power supply phase	B	Output for minimum overrun opening reached (phase) (*)
N	Power supply neutral	11	S3 output auxiliary limit switch (COM)
D1	Digital input 1 (phase)	12	S3 output auxiliary limit switch (NO)
D2	Digital input 2 (phase)	13	S3 output auxiliary limit switch (NC)
D3	Digital input 3 (phase)	14	S4 output auxiliary limit switch (COM)
D4	Digital input 4 (phase)	15	S4 output auxiliary limit switch (NO)
A	Output for maximum overrun opening reached (phase) (*)	16	S4 output auxiliary limit switch (NC)

(\*) The overrun outputs are activated only for a few moments after reaching their limit positions.

**OVERALL DIMENSIONS**

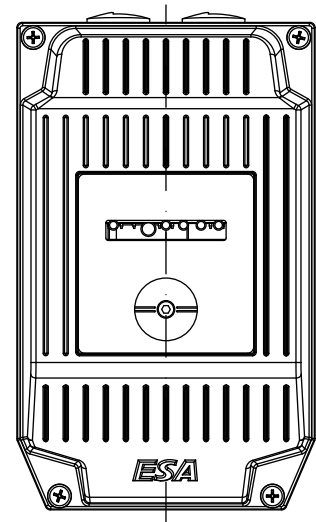
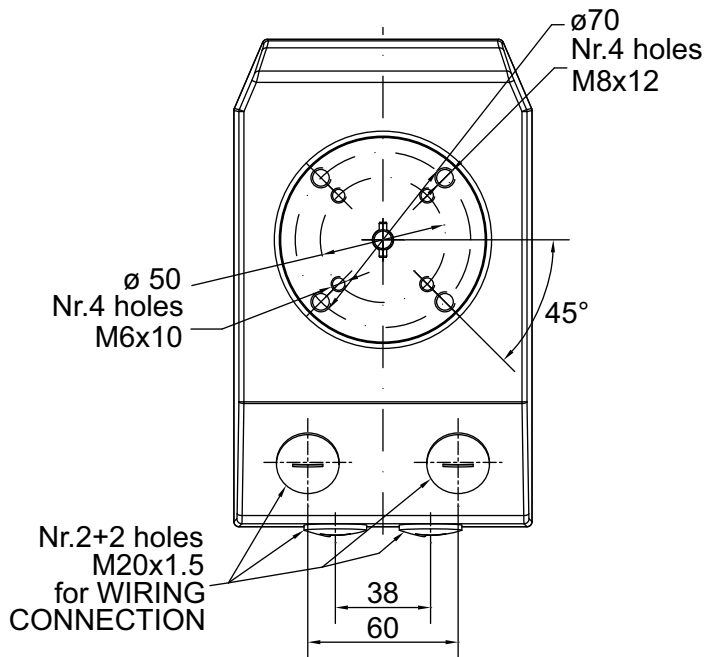
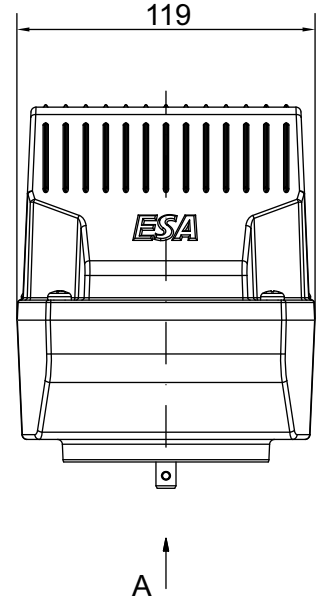
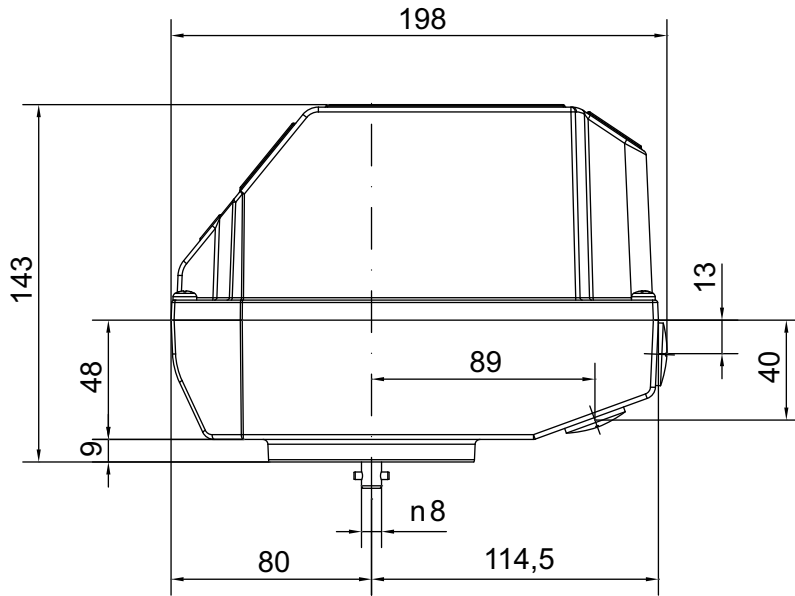

D7301105

**ORDERING CODE**

ESA SERIO TPF

01	02	03	04	05	06	07	08	09	10	11	12	13	14	15
----	----	----	----	----	----	----	----	----	----	----	----	----	----	----

<b>TORQUE OUTPUT SHAFT:</b>		<b>01</b>
5Nm	05	

<b>ROTATION TIME ON 90°</b>		<b>02</b>
12 sec	1	
60 sec	6	

<b>SUPPLY VOLTAGE</b>		<b>03</b>
230Vac	2	
115Vac	1	
24Vac	4	

<b>POSITION REFERENCE</b>		<b>04</b>
From digital input	D	

<b>COMMAND TYPE</b>		<b>05</b>
From digital input	D	

<b>FEEDBACK TYPE</b>		<b>06</b>
Not available	/	

<b>AUXILIARY LIMIT SWITCH</b>		<b>07</b>
Not available	/	
1 limit switch	1	
2 limit switches (*)	2	

<b>08</b>	<b>SERIAL COMMUNICATION</b>	
	Not available	/

<b>09</b>	<b>SERIAL COMMUNICATION TIMEOUT</b>	
	Not available	/

<b>10</b>	<b>SERIAL COMMUNICATION BAUDRATE</b>	
	Not available	/

<b>11</b>	<b>AVAILABLE PARAMETER</b>	
	No associated function	/

<b>12</b>	<b>AVAILABLE PARAMETER</b>	
	No associated function	/

<b>13</b>	<b>AVAILABLE PARAMETER</b>	
	No associated function	/

<b>14</b>	<b>AVAILABLE PARAMETER</b>	
	No associated function	/

<b>15</b>	<b>AVAILABLE PARAMETER</b>	
	No associated function	/

(\*) Warning: in ESA SERIO TPF with reference to position D, when the auxiliary limit switches are connected to the status digital inputs and used for the reference position, they cannot be connected to other devices. Otherwise if the reference position is made with external elements (eg flow switches), the limit switches remain available to the user.