

RED-EYE GAS BURNERS

RE SERIES

FEATURES

- Mixer body: cast iron G25
- Plate: cast iron G25
- Gas tube: AISI304
- Pre-heated air: up to 450 °C
- Suitable for different types of gas: CH₄/L.P./propane/etc.
- Standard refractory block, max. temp.: 1750 °C
- Capacity range: 16 to 1500 kW
- Excellent flame stability: excess air
excess fuel
on ratio firing
- Low NO_x level.
- Wall mounting flanges to fasten the block holder to the furnace shell are threaded to allow for positioning of accessories: pilot burner, flame detectors (electrodes or UV scanners), peepsight.
- Separated air and gas inlets, mixing at discharge point, no flashback.



F3504101

APPLICATIONS

- Annealing furnaces.
- Forging furnaces.
- Frit melting furnaces.
- Reverberatory furnaces.
- Aluminium melting furnaces.
- Billets reheating furnaces.
- Aluminium holding furnaces.



F3504102



Headquarters
Esa S.r.l.
Via E. Fermi 40 I-24035 Curno (BG) - Italy
Tel. +39.035.6227411 - Fax +39.035.6227499
esa@esacombustion.it - www.esapyronics.com

International Sales
Pyronics International S.A./N.V.
Zoning Ind., 4ème rue B-6040 Jumet - Belgium
Tel +32.71.256970 - Fax +32.71.256979
marketing@pyronics.be

DESCRIPTION

Red-eye gas burners are nozzle-mixing units with a high velocity, spinning, air flow. The swirling air stream produces an anticlockwise vortex inside the refractory block. Gas enters the vortex, mixing rapidly, producing intense combustion. The shape of the burner block port works with the vortex to create a ball-shaped flame to the

furnace wall at firing rates and mixtures. Maximum furnace temperatures are obtained at high-fire with stoichiometric air and gas flows. Excess air operation allows for quite cold flame temperatures without changing the volumes of the fuel gas.

INSTALLATION

Red-eye gas burners may be installed to operate in any position. Wall mounting flanges are available to fasten the block holder to the furnace shell. Lifting eye-bolt hangers are available for furnace roof suspension installations. The inside flared face of the refractory block must be flush with the interior furnace wall. The furnace refractory should be set to leave 12.5 mm on all sides of the block. This space should be packed with flexible, refractory, ceramic fibre protected by

20 mm of refractory on all sides to allow for expansion of the walls (see technical note). Flexible connectors are recommended for air and gas connections at the burner to allow slight movement or misalignment of piping and are required when pre-heated air is involved. Air and gas connections are Pyronics' standard threaded, or welding flanged type. They may rotate by 90°.

IGNITION AND FLAME DETECTION

Red-eye gas burners must be ignited at low fire. They can be ignited with a blast pilot, PBST. The pilot burner should be cut off after ignition of the main burner therefore flame detection must be

carried out by UV-scanners placed in an anticlockwise position as compared to the pilot burner. Flame detection systems are required on all burners operating at furnace temperatures below 750°C.

Catalog No.	Pilot burner ignition		Electrode ignition	
	Ignition	Detection	Ignition	Detection
RE - 1	P64PBST	UV-2 / 6EN-150 *	(not available)	UV-2
RE - 2	P64PBST	UV-2 / 6EN-150 *	(not available)	UV-2
RE - 3	P64PBST	UV-2 / 6EN-150 *	(not available)	UV-2
RE - 4	P64PBST	UV-2 / 6EN-150 *	(not available)	UV-2
RE - 5	P64PBST	UV-2 / 6EN-300 *	(not available)	UV-2
RE - 6	P64PBST	UV-2 / 6EN-300 *	(not available)	UV-2
RE - 7	P86PBST	UV-2 / 6EN-300 *	(not available)	UV-2
RE - 8	P86PBST	UV-2 / 6EN-300 *	(not available)	UV-2

(*) In most cases, we suggest you to make flame detection through UV- scanner. In some particular cases, it is possible to use continue pilot burner with detection electrode.

CAPACITY TABLE

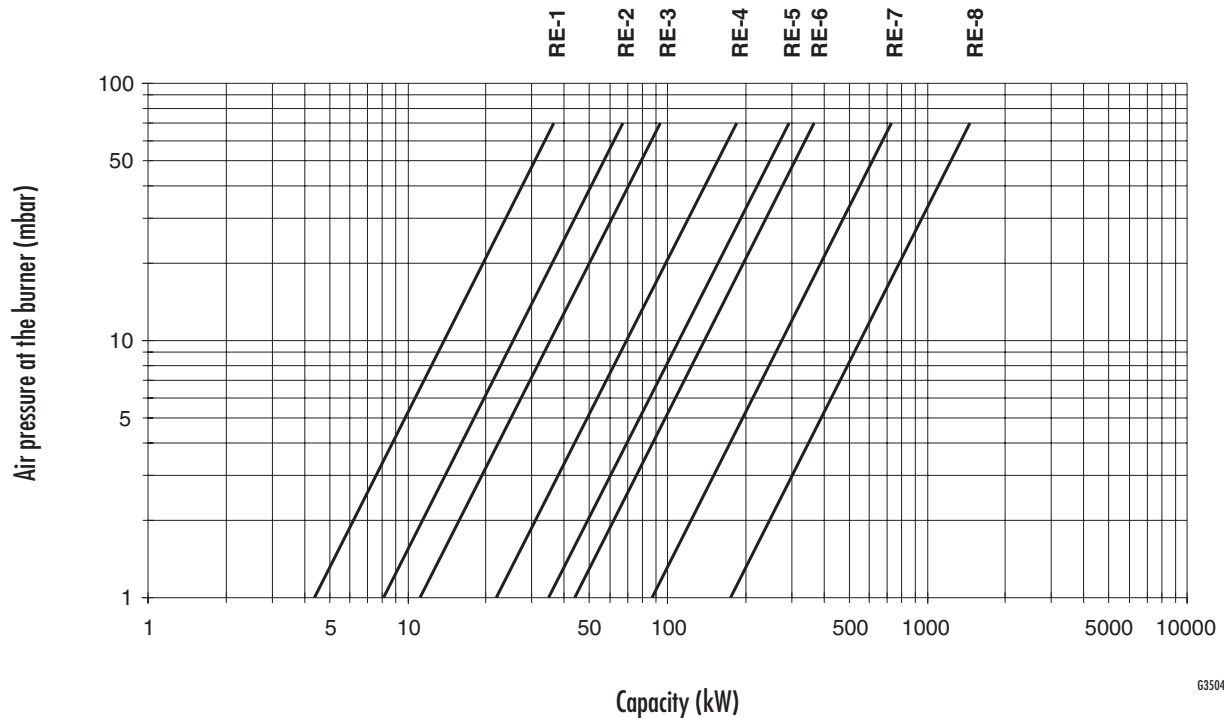

G3504101

CAPACITY TABLE

Catalog no.	Capacity (kW) with various air pressures at burner (mbar)					Pipe size		Flame length mm ⁽³⁾
	0.7	17.6	35.2 ⁽¹⁾	52.8	70.4 ⁽²⁾	Air	Gas	
RE - 1	4	18	26	32	37	1.1/2"	3/4"	110 ÷ 200
RE - 2	7	34	47	59	67	1.1/2"	3/4"	110 ÷ 300
RE - 3	9	47	66	82	94	2"	1"	140 ÷ 400
RE - 4	19	92	130	163	185	2.1/2"	1"	230 ÷ 500
RE - 5	29	147	207	255	293	3"	1.1/2"	280 ÷ 750
RE - 6	37	185	261	325	369	4"	1.1/2"	280 ÷ 1000
RE - 7	73	366	516	645	733	6"	2.1/2"	410 ÷ 1350
RE - 8	147	733	1031	1289	1465	8"	3"	610 ÷ 1500

NOTE

- ¹ Gas pressures required 10 mbar above maximum air pressure used for direct loaded systems.
- ² Minimum gas pressure 10 mbar for bleed loader and excess air systems.
- ³ Flame dimensions are approximate, referred to burners fed with CH₄, working at stoichiometric ratio, in free air. Values are included in a range: minimum value is referred to burner working at nominal capacity ⁽¹⁾, higher value at maximum capacity ⁽²⁾.

FLOW CHART (ON RATIO OPERATION)

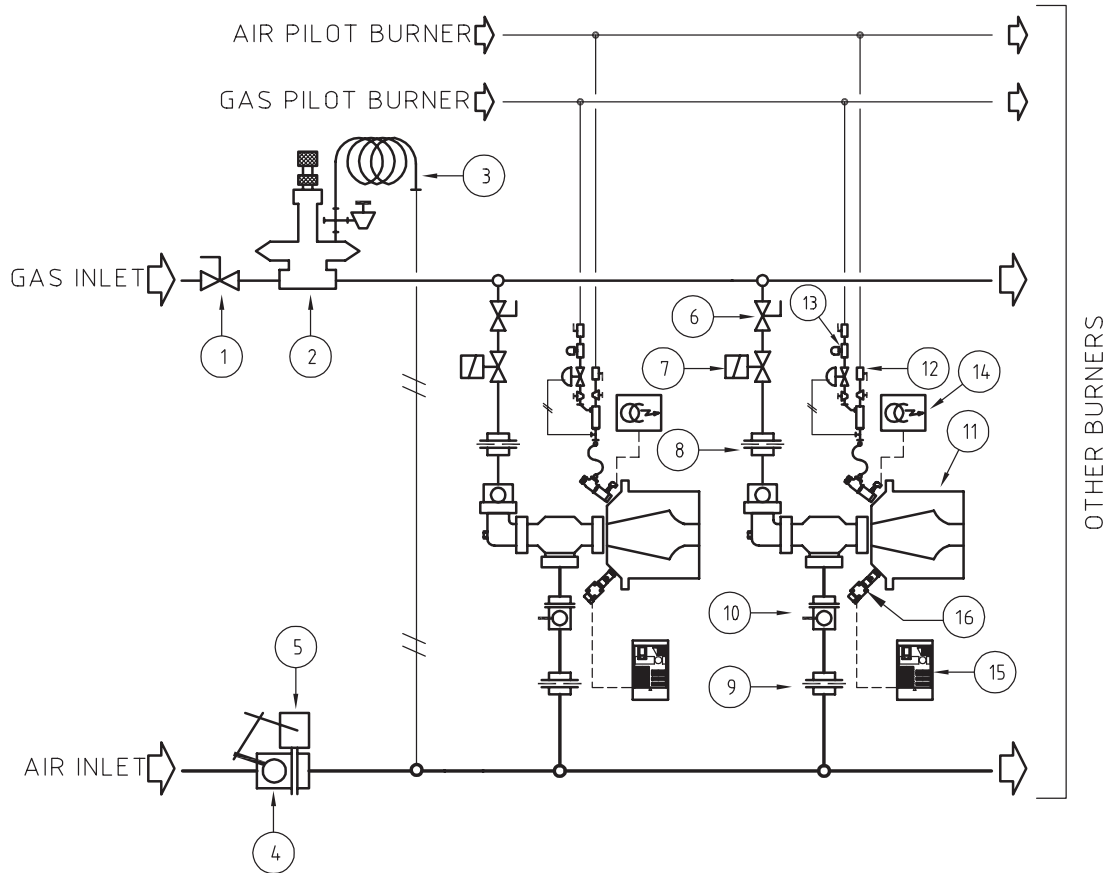

Pos.	Model identification	Pos.	Model identification
1	Gas ball valve	9	Orifice flow meter for ΔP air
2	Balanced zero regulator	10	Manual air butterfly valve
3	Impulse line	11	Red-eye gas burner
4	Motorized air butterfly valve	12	Pilot burner
5	Electric control	13	Pilot burner safety solenoid gas valve
6	Gas ball valve at each burner	14	Ignition transformer
7	Main burner safety solenoid gas valve	15	Flame detection
8	Orifice flow meter for ΔP gas	16	UV-scanner

D3504101

FLOW CHART (EXCESS AIR)

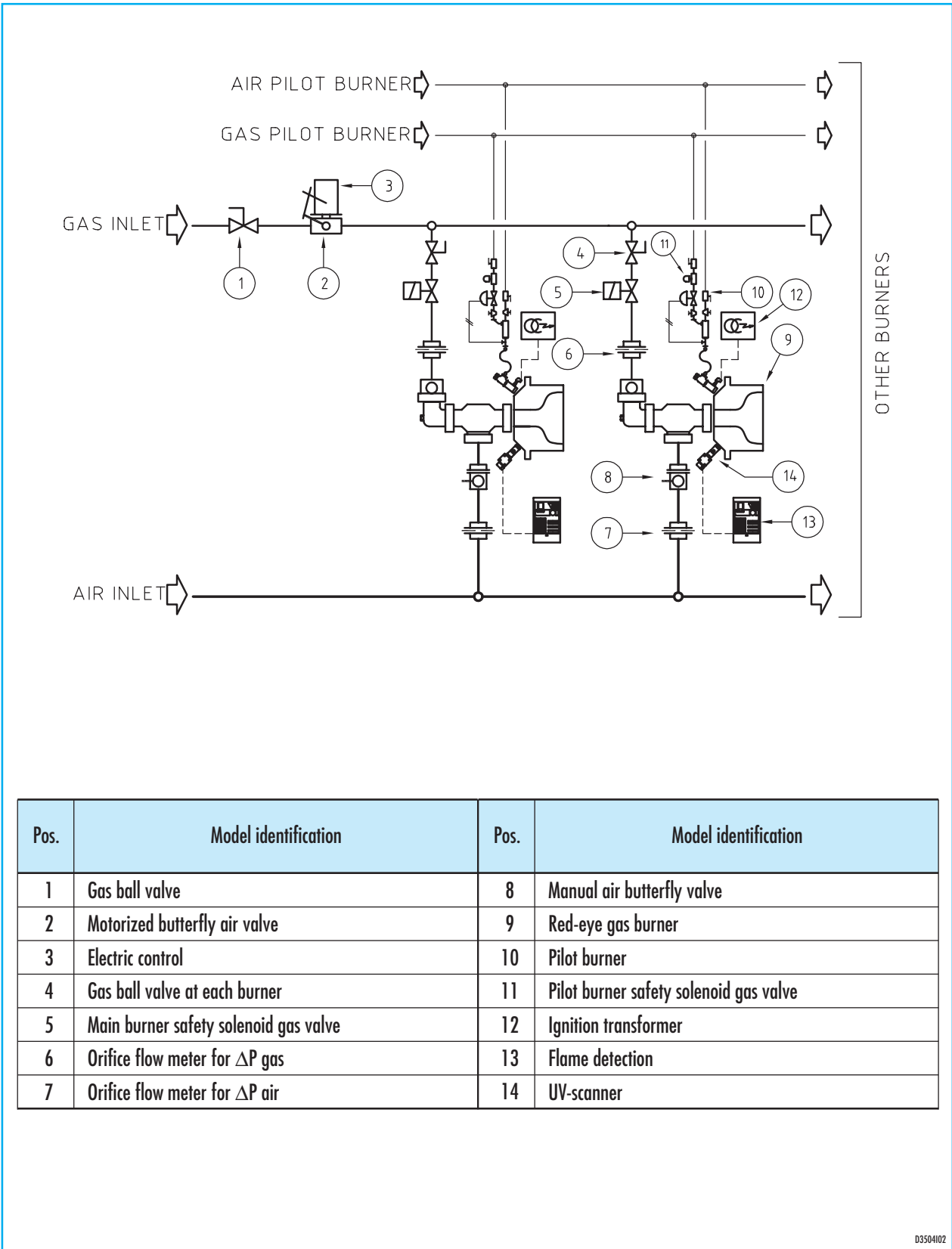

Pos.	Model identification	Pos.	Model identification
1	Gas ball valve	8	Manual air butterfly valve
2	Motorized butterfly air valve	9	Red-eye gas burner
3	Electric control	10	Pilot burner
4	Gas ball valve at each burner	11	Pilot burner safety solenoid gas valve
5	Main burner safety solenoid gas valve	12	Ignition transformer
6	Orifice flow meter for ΔP gas	13	Flame detection
7	Orifice flow meter for ΔP air	14	UV-scanner

D3504102

DIMENSIONS

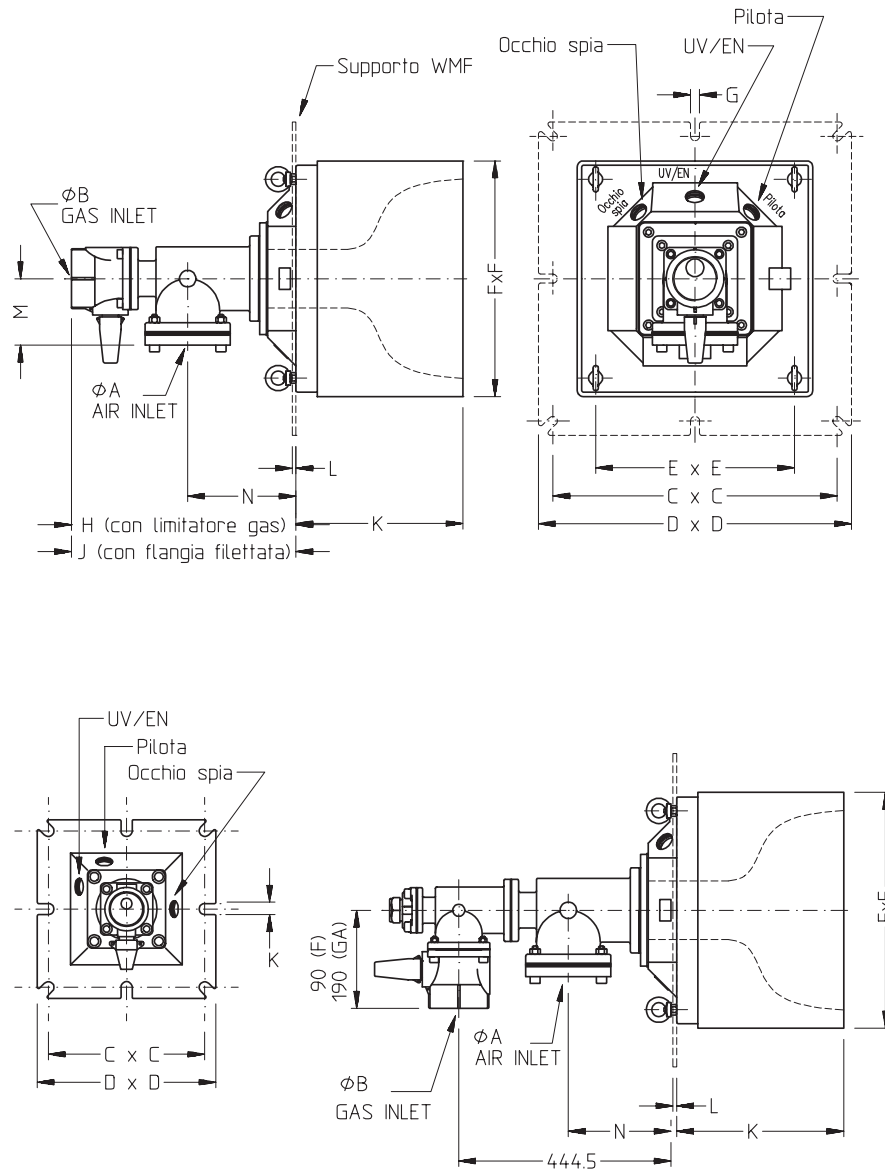

Catalog no.	Pilot	UV/EN	Peep-sight	A aria	B gas	C mm	D mm	E mm	F mm	G mm	H mm	J mm	K mm	L mm	M mm	N mm
RE - 1	G-3/4"	G-3/4"	G-3/4"	G-1.1/2"	G-3/4"	222	254	—	178	14	200	175	241	9	80	121
RE - 2	G-3/4"	G-3/4"	G-3/4"	G-1.1/2"	G-3/4"	222	254	—	178	14	200	175	241	9	80	121
RE - 3	G-3/4"	G-1"	G-3/4"	G-1.1/2"	G-1"	222	254	—	178	14	200	175	241	9	80	121
RE - 4	G-3/4"	G-1"	G-3/4"	G-2"	G-1"	394	430	286	343	16	250	225	241	5	86	145
RE - 5	G-3/4"	G-1"	G-3/4"	DN65	G-1.1/2"	394	430	286	343	16	300	273	241	5	110	165
RE - 6	G-3/4"	G-1"	G-3/4"	DN80	G-1.1/2"	394	430	286	343	16	300	273	241	5	110	165
RE - 7	G-1"	G-1"	G-1"	DN100	G-2.1/2"	564	610	406	533	16	380	318	470	5	136	180
RE - 8	G-1"	G-1"	G-1"	DN150	G-3"	635	737	457	762	16	380	318	470	5	136	203

D3504E03

ORDERING CODES - BURNER

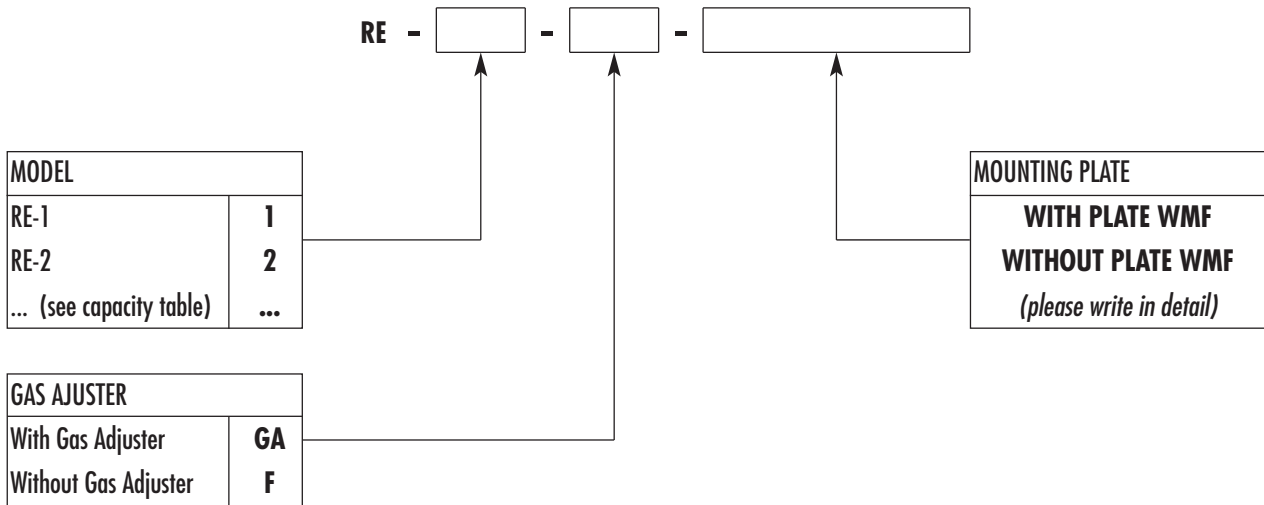

ORDERING CODES - REFRACTORY BLOCK ONLY

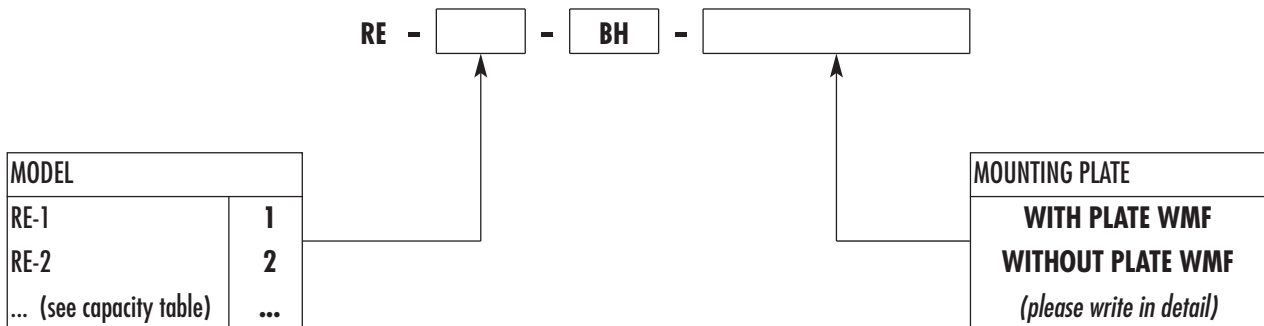

NOTE: Based on the company's policy aimed at a continuous improvement on product quality, ESA-PYRONICS reserves the right to bring changes to the technical characteristics of this device without previous notice. Our catalog updated to the latest version is available on our web site www.esapyronics.com and it is possible to download modified documents

WARNING: When operating, this combustion system can be dangerous and cause harm to persons or damage to equipment. Every burner must be provided with a protection device that monitors the combustion. The installation, adjustment and maintenance operations should only be performed by trained and qualified personnel.