

# FLAT FLAME AND EXCESS AIR BURNERS SIDEWINDER - SW SERIES

## FEATURES

- Mixer body: cast iron G25
- Plate: cast iron G25
- Gas tube: AISI304
- Pre-heated air: up to 450°
- Suitable for different types of gas: CH4 /L.P./propane/etc.
- Standard refractory block, max. temp.: 1750°C
- Capacity range: 16 to 1500 kW
- Excellent flame stability: excess air  
excess fuel  
on ratio firing
- Low NO<sub>x</sub> level.
- Wall mounting flanges to fasten the block holder to the furnace shell are threaded to allow for positioning of accessories: pilot burner, flame detectors (electrodes or UV scanners), peepsight.
- Separated air and gas inlets, mixing at discharge point, no flashback.

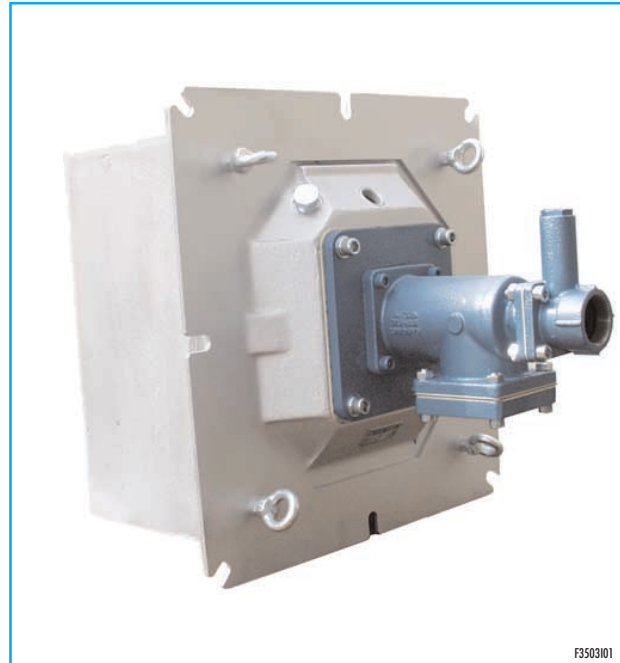

F3503101

## APPLICATIONS

- Cap annealing furnaces.
- Reverberatory furnaces.
- Aluminium melting furnaces.
- Zinc melting furnaces.
- Cone and pit furnaces.
- Billets reheating furnaces.



F3503102

## DESCRIPTION

Sidewinder gas burners are nozzle-mixing units with a high velocity, spinning, air flow. The swirling air stream produces an anticlockwise vortex inside the refractory block. Gas enters the vortex, mixing rapidly, producing intense combustion. The inverted parabolic shape of the burner block port works with the vortex to pull flames flat to

the furnace wall at firing rates and mixtures. Maximum furnace temperatures are obtained at high-fire with stoichiometric air and gas flows. Excess air operation allows for obtaining quite cold flame temperatures without changing the volumes of the fuel gas.

## INSTALLATION

Sidewinder gas burners may be installed to operate in any position. Wall mounting flanges are available to fasten the block holder to the furnace shell. Lifting eye-bolt hangers are available for furnace roof suspension installations. The inside flared face of the refractory block must be flush with the interior furnace wall. The furnace refractory should be set to leave 12.5 mm on all sides of the block. This space should be packed with flexible, refractory, ceramic fibre protected by

20 mm of refractory concrete on all sides to allow for expansion of the walls. Flexible connectors are recommended for air and gas connections at the burner to allow slight movement or misalignment of piping and are required when pre-heated air is involved. Air and gas connections are Pyronics' standard threaded, or welding flanged type. They may rotate by 90°.

## IGNITION AND FLAME DETECTION

Sidewinder gas burners must be ignited at low fire. They can be ignited with a blast pilot, P86PBST, or electrode DSE. The pilot burner should be cut off after the ignition of the main burner therefore flame detection must be carried out by UV-scanners placed in an

anticlockwise position as compared to the pilot burner. Flame detection systems are required on all burners operating at furnace temperatures below 750°C.

Catalog No.	Pilot burner ignition		Electrode ignition	
	Ignition	Detection	Ignition	Detection
SW-1	P64PBST	UV-2 / 6EN-150 *	DSE-6	UV-2
SW-2	P64PBST	UV-2 / 6EN-150 *	DSE-7	UV-2
SW-3	P64PBST	UV-2 / 6EN-150 *	DSE-7	UV-2
SW-4	P64PBST	UV-2 / 6EN-150 *	DSE-7	UV-2
SW-5	P64PBST	UV-2 / 6EN-300 *	DSE-8	UV-2
SW-6	P86PBST	UV-2 / 6EN-300 *	DSE-8	UV-2
SW-7	P86PBST	UV-2 / 6EN-300 *	(not available)	(not available)
SW-8	P86PBST	UV-2 / 6EN-300 *	(not available)	(not available)

(\*) In most cases, we suggest you to make flame detection through UV- scanner. In some particular cases, it is possible to use continue pilot burner with detection electrode.

### CAPACITY TABLE

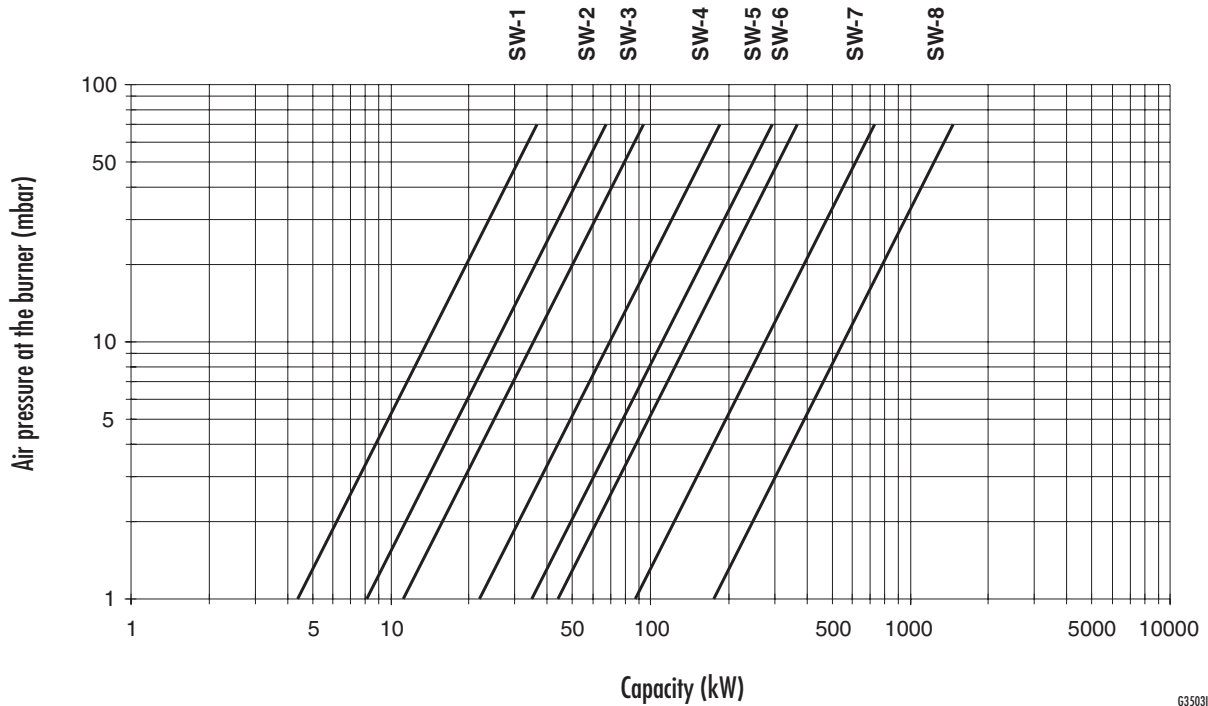

63503101

### CAPACITY TABLE

Catalog no.	kW with different burner air inlet pressure (mbar) *					Recommended pipe runs for each burner	
	0.7	17.6	35.2	52.8	70.4	Air	Gas
SW-1	4	18	26	32	37	1.1/2"	3/4"
SW-2	7	34	47	59	67	1.1/2"	3/4"
SW-3	9	47	66	82	94	2"	1"
SW-4	19	92	130	163	185	2.1/2"	1"
SW-5	29	147	207	255	293	3"	1.1/2"
SW-6	37	185	261	325	369	4"	1.1/2"
SW-7	73	366	516	645	733	6"	2.1/2"
SW-8	147	733	1031	1289	1465	8"	3"

Ratio 5:1

Ratio 7:1

Ratio 8.5:1

Ratio 10:1

Turndown capability from various air pressures at burner

\* Burner ratings achieved with: 26 mbar gas pressure to ratio regulator (BZR); bleed loader set at 15 mbar (2TDL-B); balanced combustion chamber pressure; natural gas or L.P.

## FLOW CHART (ON RATIO OPERATION)

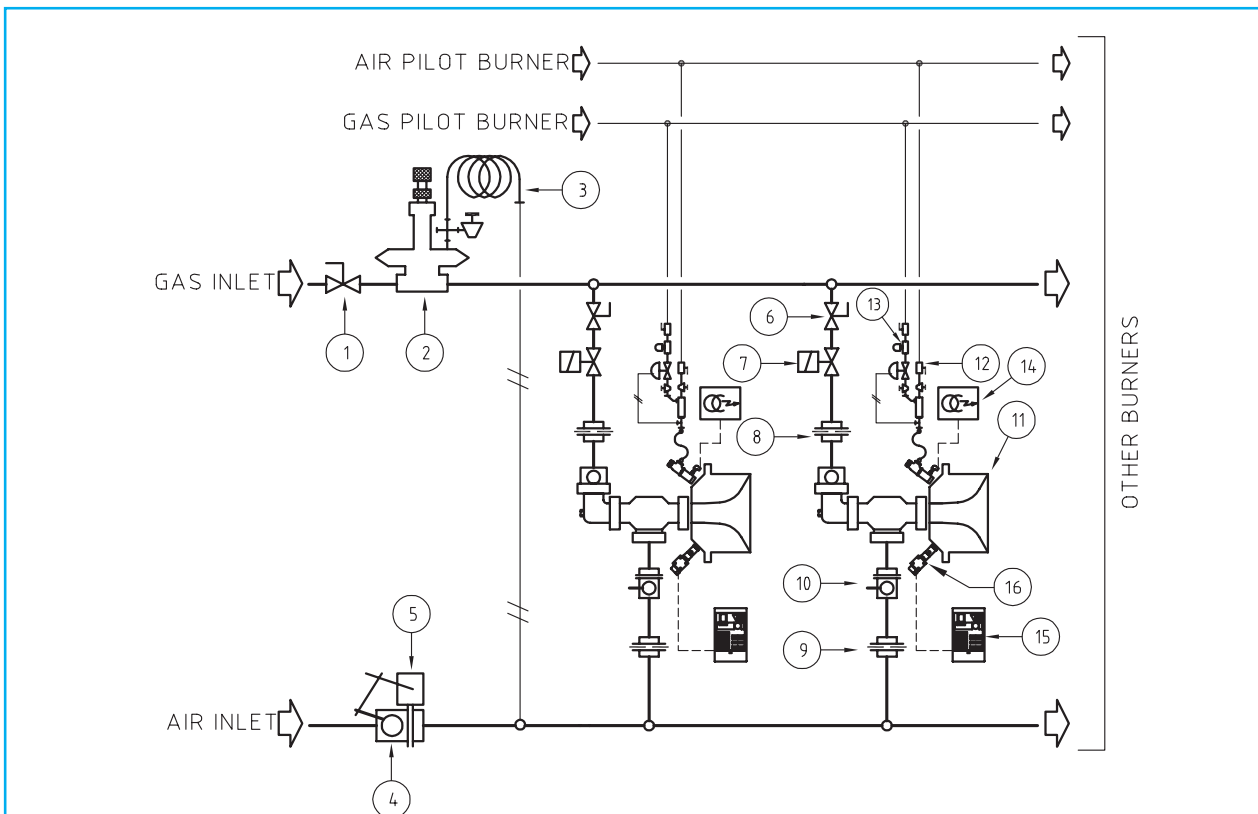

Pos.	Model identification
1	Gas ball valve
2	Balanced zero regulator
3	Impulse line
4	Motorized air butterfly valve
5	Electric control
6	Gas ball valve at each burner
7	Main burner safety solenoid gas valve
8	Orifice flow meter for $\Delta P$ gas
9	Orifice flow meter for $\Delta P$ air
10	Manual air butterfly valve
11	Flat flame burner
12	Pilot burner
13	Pilot burner safety solenoid gas valve
14	Ignition transformer
15	Flame detection
16	UV-scanner

D350301

## FLOW CHART (EXCESS AIR)

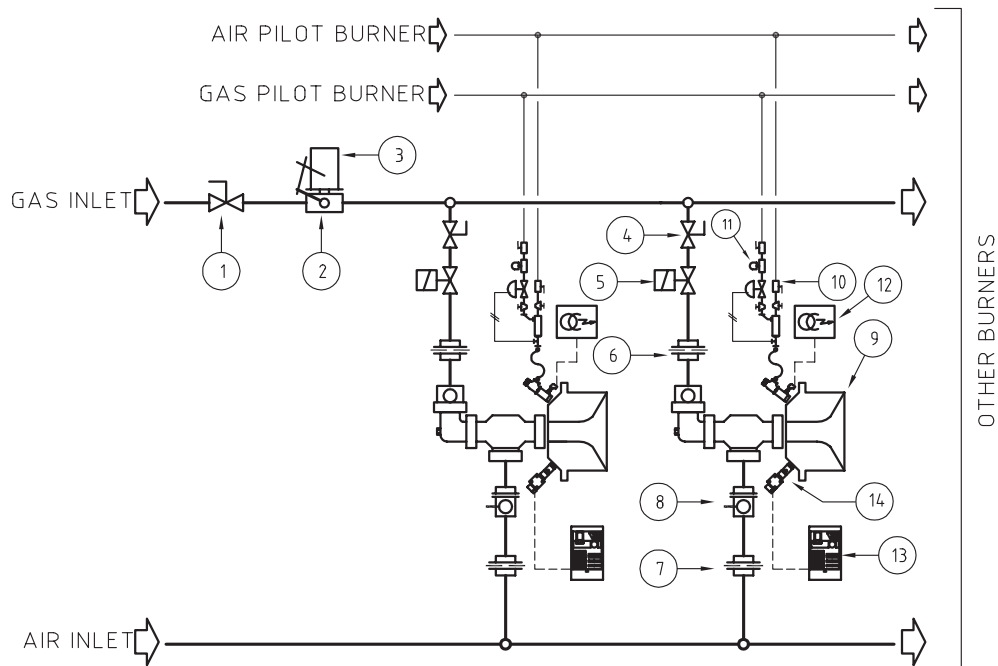

Pos.	Model identification
1	Gas ball valve
2	Motorized butterfly air valve
3	Electric control
4	Gas ball valve at each burner
5	Main burner safety solenoid gas valve
6	Orifice flow meter for $\Delta P$ gas
7	Orifice flow meter for $\Delta P$ air
8	Manual air butterfly valve
9	Flat flame burner
10	Pilot burner
11	Pilot burner safety solenoid gas valve
12	Ignition transformer
13	Flame detection
14	UV-scanner

D3503102

## DIMENSIONS

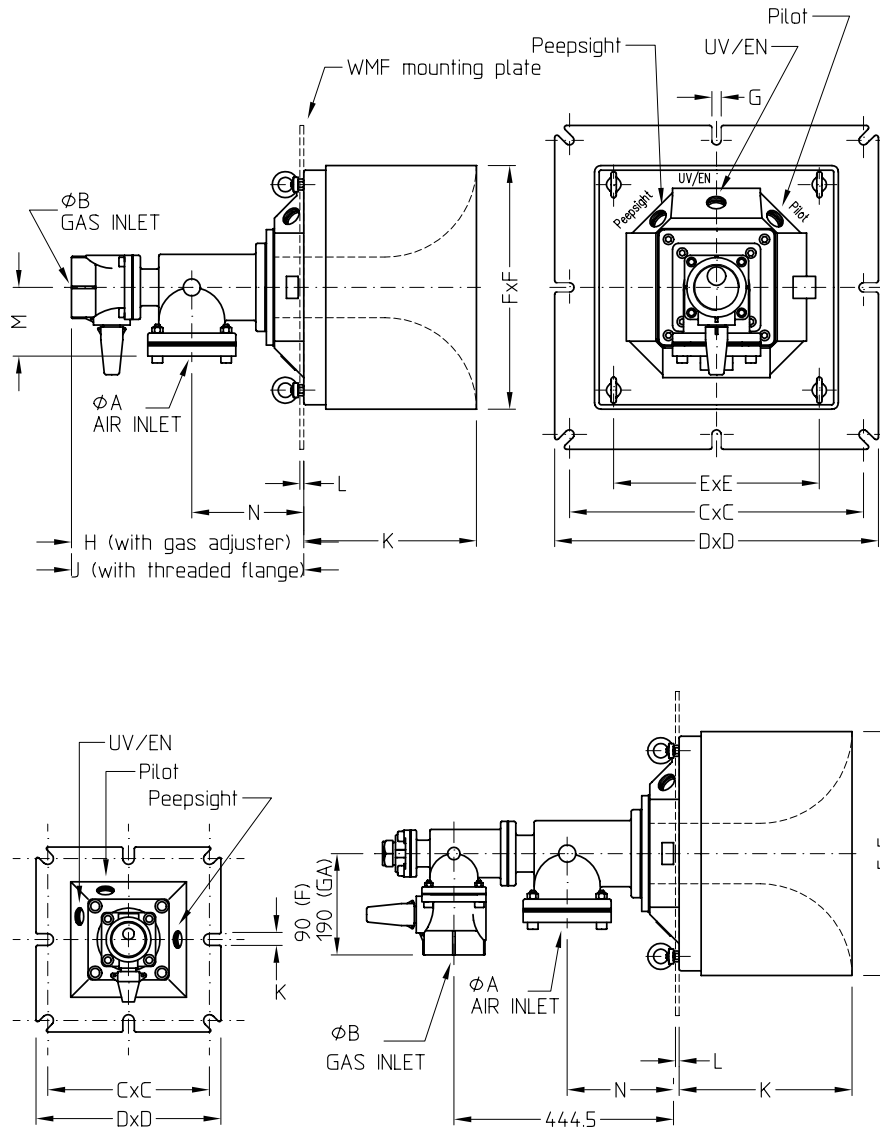

D3503E03

Catalog no.	Pilot	UV-EN	Peep-sight	A	B	C mm	D mm	E mm	F mm	G mm	H mm	J mm	K mm	L mm	M mm	N mm
SW-1	G-3/4"	G-3/4"	G-3/4"	G-1.1/2"	G-3/4"	222	254	-	178	14	210	184	241	9	83	121
SW-2	G-3/4"	G-3/4"	G-3/4"	G-1.1/2"	G-3/4"	394	430	286	343	16	238	213	241	5	83	149
SW-3	G-3/4"	G-3/4"	G-3/4"	G-1.1/2"	G-1"	394	430	286	343	16	238	213	241	5	83	149
SW-4	G-3/4"	G-3/4"	G-3/4"	G-2"	G-1"	394	430	286	343	16	238	213	241	5	83	159
SW-5	G-3/4"	G-3/4"	G-3/4"	DN65	G-1.1/2"	464	508	356	419	16	308	283	241	5	111	175
SW-6	G-3/4"	G-3/4"	G-3/4"	DN80	G-1.1/2"	464	508	356	419	16	308	283	241	5	111	175
SW-7	G-1"	G-1"	G-1"	DN100	G-2.1/2"	464	508	356	419	16	308	283	241	5	140	191
SW-7.1/2"	G-1"	G-1"	G-1"	DN150	G-3"	464	508	356	419	16	-	-	241	5	-	203
SW-8	G-1"	G-1"	G-1"	DN150	G-3"	564	610	406	533	16	-	-	241	5	-	203

## BURNER SELECTION TABLE

Catalog no.	Maximum pilot mix. pressure with max main air to burner (mbar)	Max % excess air - 70 mbar		Approx. flame diameter		Minimum burner spacing (on ratio)	
		with pilot	without pilot	on ratio at maximum rating (mm)	75% aeration with maximum air at burner	between burners (mm)	burner to load - min. (mm)
SW-1	2,5	2000	1200	300	460	460	300
SW-2	5	2000	1500	400	600	610	300
SW-3	6,3	2000	600	600	800	910	300
SW-4	6,3	2000	900	650	920	1000	460
SW-5	7,5	2000	700	750	1200	1150	460
SW-6	8,7	2000	540	900	1400	1400	460
SW-7	15	2000	700	1500	2300	1800	460
SW-8	15	2000	400	1800	-	2100	610

## NOTE

Flame length are approximate, referred to burner feeded with natural gas, free air, working at stoichiometric ratio and at nominal capacity. when two different sizes of burners are mounted adjacent to each other, minimum spacing for larger burner must be used.

ORDERING CODES - BURNER

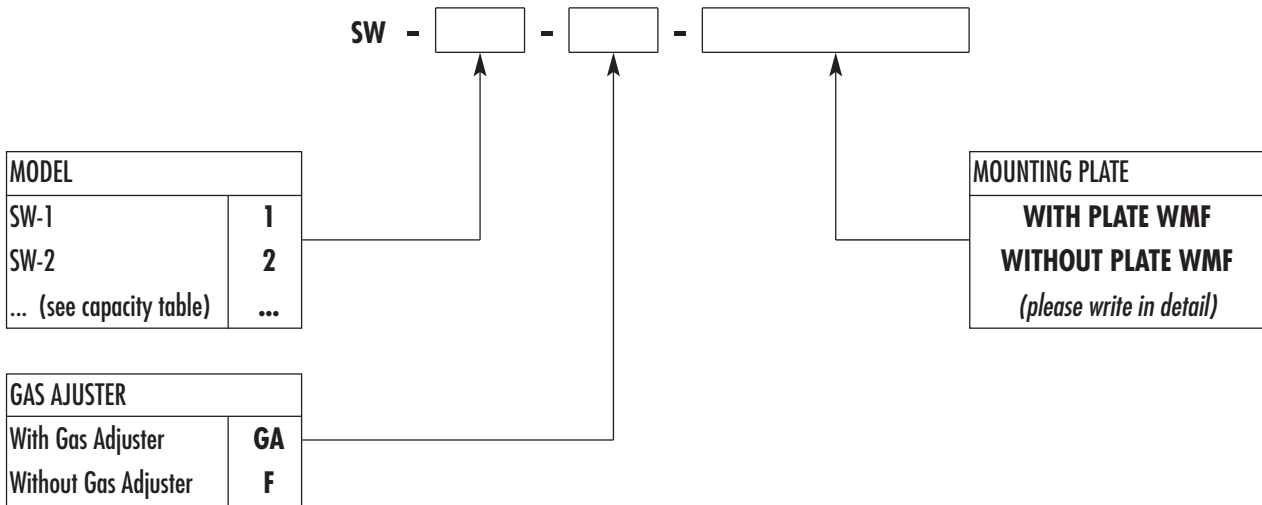

ORDERING CODES - REFRACTORY BLOCK ONLY

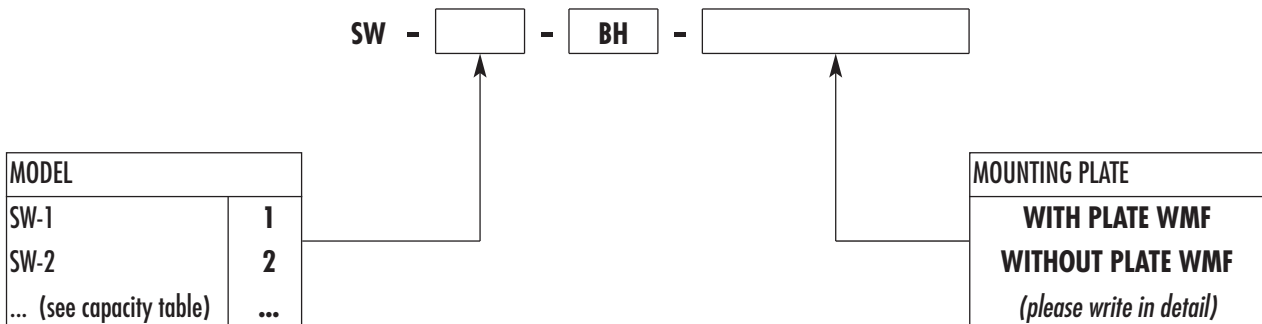

NOTE: Based on the company's policy aimed at a continuous improvement on product quality, ESA-PYRONICS reserves the right to bring changes to the technical characteristics of this device without previous notice. Our catalog updated to the latest version is available on our web site [www.esapyronics.com](http://www.esapyronics.com) and it is possible to download modified documents

WARNING: When operating, this combustion system can be dangerous and cause harm to persons or damage to equipment. Every burner must be provided with a protection device that monitors the combustion. The installation, adjustment and maintenance operations should only be performed by trained and qualified personnel.